



Precision • Quality • Delivery  
Custom Solutions



**PETROCHEMICAL**  
Flange Fittings Manufacturing Inc.





About Us .....	4
Material & Manufacturing Steel .....	5
Standard Finish .....	6
Tolerance .....	7
Tolerance Pipe .....	8
Welding End .....	9
Ansi Flang .....	10
Class 150 Flanges .....	11-12
Class 300 Flanges .....	13-14
Class 400 Flanges .....	15-16
Class 600 Flanges .....	17-18
Class 900 Flanges .....	19-20
Class 1500 Flanges .....	21-22
Class 2500 Flanges .....	23-24
Reducing Flanges .....	25-26
Classess Available .....	27
Flange Facing And Finishing .....	28
Production Process .....	29
Ring Joint Flanges .....	30
Class 150 Flanges .....	31
Class 300 Flanges .....	32
Class 900 Flanges .....	33
Class 1500 Flanges .....	34
Class 2500 Flanges .....	35
Our Services .....	36-37
JIS/KS Flanges .....	39
Class 5k Flanges .....	40
Class 10k Flanges .....	41
Class 16k Flanges .....	42
Class 20k Flanges .....	43
Class 30k Flanges .....	44
210kgf/cm2 Jis B2291 Square Flanges .....	45
Product Range .....	46-47
Din Flange – Slip-on/blind/weld .....	48
Din 2543, 2527, 2633 .....	49
Din 2544, 2527, 2634 .....	50
Din 2545, 2527, 2635 .....	51
Din 2573, 2527, 2637 .....	52
Din 2576, 2527, 2632 .....	53
Fittings .....	54-55
Buttweld Fittings .....	56-57
ASME B 16.9 Elbow .....	58
ASME B 16.9 Elbow Tee/Cross/Return .....	59-60
ASME B 16.9 Elbow Lap Joint .....	63
ASME B 16.9 Elbow Caps .....	64
ASME B 16.9 Elbow Reducers .....	65





# About Us

## PetroChemical Flange Fittings Manufacturing Inc.

We are specialized in the manufacturing and distribution of forge stainless steel and carbon steel flange and fittings. With the commitment of quality products and timely delivery, Our Company has achieved 100% satisfaction of our clients and continues to build strong relationship with our clients worldwide.

We have first-class inspection devices, perfect detecting means and well-trained specialists. And we stick to ISO 9001:2008 quality systems and efficiently control procedure in production. We have confidence about our best quality products with competitive prices.

We are based in Canada and have distribution office in UK, USA and the Gulf region.

### STANDARD:

**ASME** B16.5, ASME B16.47, ANSI B16.36, AWWA

**DIN** 2527, DIN 2573, DIN 2576, DIN 2575, DIN 2630, DIN 2631, DIN 2632, DIN 2633, DIN 2634, DIN 2635, DIN 2636, DIN 2637, DIN 2641, DIN 2642, DIN 2652

**EN** 1092-1, **JIS** B2220

### FLANGE:

**Stainless Steel:** ASTM A182 F304/ 304L/ 304H/ 316/ 316L/ 317/ 317L/ 321/ 310/ 347/904L etc.

**Carbon Steel:** ASTM A105/ A105N/ A694 F42/46/52/56/60/65/70 / A350 LF3/ A350 LF2 **Alloy Steel:** ASTM A182 F1/ F5/ F9/ F11/ F22/ F91/ etc.

**Types:** Weldneck , Slipon, Blind, Socket Weld , Lap Joint, Spectacles, Ring Joint, Orifice, Long Weldneck, Deck Flange, etc.

**Size:** 1/2" NB TO 48" NB. Class: 150#, 300#, 400#, 600#, 900#, 1500# & 2500#.

### FORGED HIGH PRESSURE FITTINGS

**Carbon Steel:** ASTM A105/ A105N/ A694 F42/46/52/56/60/65/70 / A350 LF3/ A350 LF2

**Stainless Steel:** ASTM A182 F304/ 304L/ 304H/ 316/ 316L/ 317/ 317L/ 321/ 310/ 347/904L etc.

**Alloy Steel:** ASTM A182 F1/ F5/ F9/ F11/ F22/ F91/ etc.

**Types :** Elbow, Tee, Union, Cross, Coupling, Cap, Bushing , Plug, Swage Nipple, Welding Boss, Hexagon Nipple, Barrel Nipple, Welding Nipple, Parallel Nipple, Street Elbow, Hexagon Nut, Hose Nipple, Bend, Adapter, Insert, Cross, Weldolet, Sockolet, Thredolet, etc.

Please send all enquires: [sales@petrocff.com](mailto:sales@petrocff.com)

**PetroChemical Flange Fittings Manufacturing Inc**

**Phone: 1- 866-590-3835**

**Fax: 1-866-315-8484**

**Email: [sales@petrocff.com](mailto:sales@petrocff.com)**

**[www.petrocff.com](http://www.petrocff.com)**

**1744 Meyerside Drive**

**Mississauga, ON L5T 1A3, CANADA**

**Precision . Quality . Delivery . Custom Solutions**





## FLANGES STANDARDS

There are many different flange standards to be found worldwide. To allow easy functionality and inter-changeability, these are designed to have standardized dimensions. Common world standards include ASA/ANSI/ASME (USA), PN/DIN (European), BS10 (British/Australian), and JIS/KS (Japanese/Korean). In most cases these are not interchangeable (e.g. an ANSI/ASME flange will not mate against a JIS flange).

Further, many of the flanges in each standard are divided into “pressure classes”, allowing flanges to be capable of taking different pressure ratings. Again these are not generally interchangeable (e.g. an ANSI/ASME 150 will not mate with an ANSI/ASME 300). These pressure classes also have differing pressure and temperature ratings for different materials.

Unique pressure classes for piping can also be developed for a process plant or power generating station; these may be specific to the corporation, engineering procurement and construction (EPC) contractor, or the process plant owner.

The ANSI/ASME pressure classes for Flat-Face flanges are 125# and 250#. The classes for Ring-Joint, Tongue & Groove, and Raised-Face flanges are 150#, 300#, (400# - unusual), 600#, 900#, 1500#, and 2500#

The flange faces are also made to standardized dimensions and are typically “flat face”, “raised face”, “tongue and groove”, or “ring joint” styles, although other obscure styles are possible. Flange designs are available as “weld neck”, “slip-on”, “lap joint”, “socket weld”, “threaded”, and also “blind”.

## ASME STANDARD

Pipe flanges that are made to standards called out by ASME B16.5 or ASME B16.47 are typically made from forged materials and have machined surfaces. B16.5 refers to nominal pipe sizes (NPS) from ½” to 24”. B16.47 covers NPSs from 26” to 60”. Each specification further delineates flanges into pressure classes: 150, 300, 400, 600, 900, 1500 and 2500 psi for B16.5; B16.47 delineates its flanges into pressure classes 75, 150, 300, 400, 600, 900.

# STANDARD FINISH

## Standard Finishes for Face of Flange(ANSI B16.5)

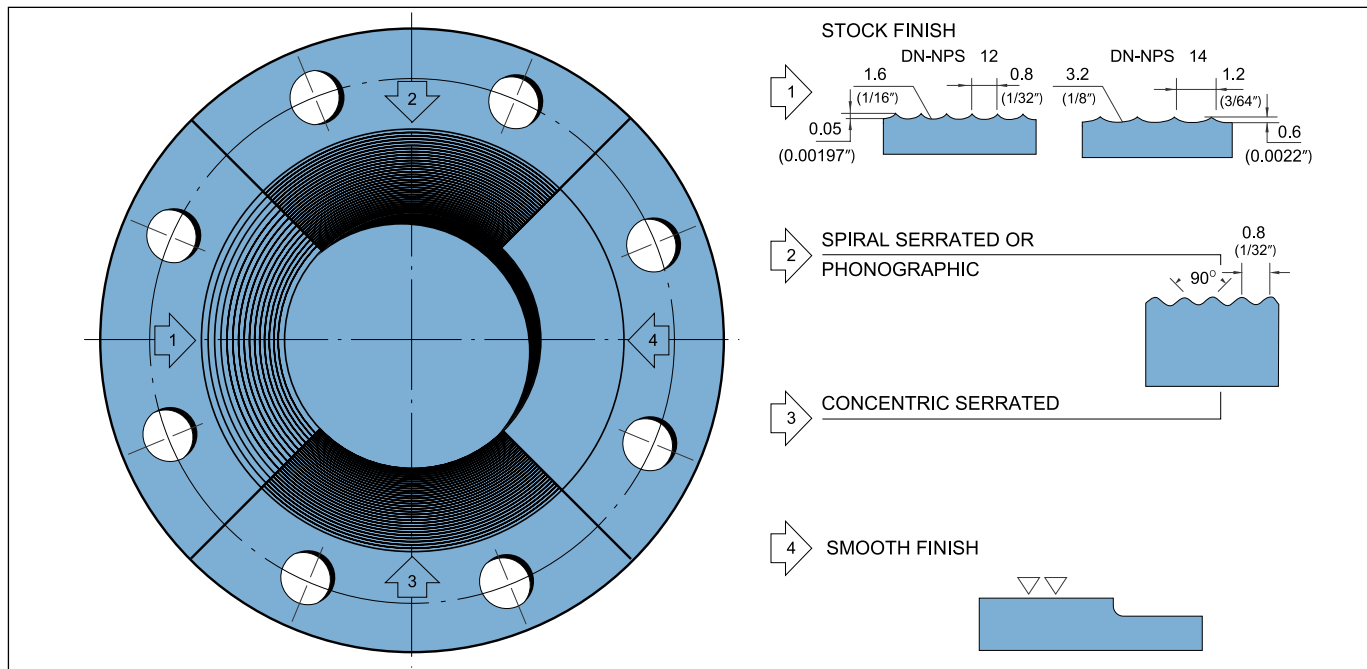

**STOCK FINISH :** The most widely used of any gasket finish, because, practically, is suitable for all ordinary service conditions. This is a continuous spiral groove. Flanges sizes 12” (304.8mm) and smaller, are produced with a 1/16” round nosed tool at a feed of 1/32” per revolution. For sizes 14” (355.6mm) and larger, the finish is made with 1/8” round-nosed tool at a feed of 3/64” per revolution.

**SPIRAL SERRATED OR PHONOGRAPHIC :** This finish is produced by using a 90° round nosed tool.

**CONCENTRIC SERRATED :** This finish is produced by using a 90° round nosed tool.

**SMOOTH FINISH :** The cutting tool employed shall have an approximate 0.06” radius. The resultant surface finish shall have a 125 μ inch to 250 μ inch (ANSI B 16.5 para 6, 4, 4)

■ **RAISED FACE, AND LARGE MALE AND FEMALE**

Either a serrated-concentric or serrated-spiral finish having from 45 to 55 grooves per inch is used. The cutting tool employed has an approximate 0.06 in, radius. The resultant surface finish shall have a 125 μ inch (3.2μm), to 250 μ inch (6.4μm) approximate roughness.

■ **TONGUE AND GROOVE, AND SMALL MALE AND FEMALE**

The gasket contact surface does not exceed 125 μ in (3.2μm) roughness.

■ **RING JOINT**

The inside wall surface of gasket groove does not exceed 63 μ in (1.6μm) roughness.

■ **BLIND**

Blind flanges need not be faced in the center if, when this center part is raised, its diameter is at least 1 in smaller than the inside diameter of fittings of the corresponding pressure class. When the center part is depressed, its diameter is not greater than the inside diameter of the corresponding pressure class fittings. Maching of the depressed center is not required.

## TOLERANCE

### ANSI B16.5 Forged Flanges

SOLID FLANGE

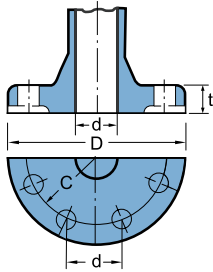

SLIP-ON FLANGE

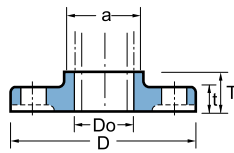

WELDING NECK FLANGE

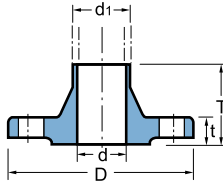

TYPE OF GASKET SURFACE

MALE & FEMALE TYPE

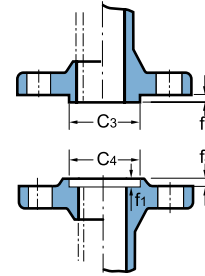

TONGUE & GROOVE TYPE

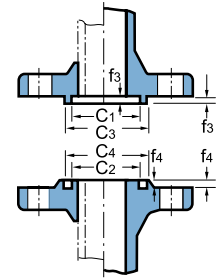

### THREADED, SOCKET-WELDING, SLIP-ON, LAP JOINT AND BLIND

Outside Diameter	When O.D. is 24" or less	$\pm 1/16"$ (1.6mm)*
	When O.D. is Over 24"	$\pm 1/8"$ (3.2mm)*
Inside Diameter	Threaded	Within limits on boring gauge
	Socket-Welding, Slip-on and Lap joint	10" & Smaller $+1/32"$ (0.8mm), $-0"$ 12" & Larger $+1/16"$ (1.6mm), $-0"$
Outside Diameter of Hub	5" and Smaller	$+3/32"$ (2.4mm)* $-1/32"$ (0.8mm)
	6" and Larger	$+5/32"$ (4.0mm) $-1/32"$ (0.8mm)
Diameter of Contact Face	1/16" Raised Face	$+1/32"$ (0.8mm)
	1/4" Raised Face Tongue & Groove Male, Female	$+1/64"$ (0.4mm)
Diameter of Counterbore	Same as for Inside Diameter	
Drilling	Bolt Circle	$\pm 1/16"$ (1.6mm)
	Bolt Hole Spacing	$\pm 1/32"$ (0.8mm)
	Eccentricity of Bolt Circle with Respect to Facing	2 1/2" & Smaller $1/32"$ (0.8mm) Max. 3" & Larger $1/16"$ (1.6mm) Max.
	Eccentricity of Bolt Circle with Respect to Bore	$1/32"$ (0.8mm) Max.*
Thickness	18" and Smaller	$+1/8"$ (3.2mm), $-0"$
	20" and Larger	$+3/16"$ (4.8mm), $-0"$
Length Thru Hub	10" and Smaller	$\pm 1/16"$ (1.6mm)
	12" and Larger	$\pm 1/8"$ (3.2mm)

NOTE : \* This tolerance is not covered in ANSI B16.5, but maker's option

### WELDING NECK

Outside Diameter	When O.D. is 24" or less	$\pm 1/16"$ (1.6mm)*
	When O.D. is Over 24"	$\pm 1/8"$ (3.2mm)*
Inside Diameter	10" and Smaller	$\pm 1/32"$ (0.8mm)
	12" thru 18"	$\pm 1/16"$ (1.6mm)
	20" and Larger	$+1/8"$ (3.2mm) $-1/16"$ (1.6mm)
Diameter of Contact Face	1/16" Raised Face	$\pm 1/32"$ (0.8mm)
	1/4" Raised Face Tongue & Groove Male, Female	$+1/64"$ (0.4mm)
Diameter of Hub at Base	When Hub Base is 24" or Smaller	$\pm 1/16"$ (1.6mm)
	When Hub Base is Over 24"	$\pm 1/8"$ (3.2mm)
Diameter of Hub at Point of Welding	5" and Smaller	$+3/32"$ (2.4mm) $-1/32"$ (0.8mm)
	6" and Larger	$+5/32"$ (4.0mm) $-1/32"$ (0.8mm)
Drilling	Bolt Circle	$\pm 1/16"$ (1.6mm)
	Bolt Hole Spacing	$\pm 1/32"$ (0.8mm)
	Eccentricity of Bolt Circle with Respect to Facing	2 1/2" & Smaller $1/32"$ (0.8mm) Max. 3" & Larger $1/16"$ (1.6mm) Max.
	Eccentricity of Bolt Circle with Respect to Bore	$1/32"$ (0.8mm) Max.*
Thickness	18" and Smaller	$+1/8"$ (3.2mm), $-0"$
	20" and Larger	$+3/16"$ (4.8mm), $-0"$
Length Thru Hub	4" and Smaller	$\pm 1/16"$ (1.6mm)
	5" ~ 10"	$+1.6$ ~ $3.0$ mm
	12" and Larger	$+3.0$ ~ $5.0$ mm

NOTE : \* This tolerance is not covered in ANSI B16.5, but maker's option



## TOLERANCE FOR PIPE FLANGES

KS B1502 / JIS B2203

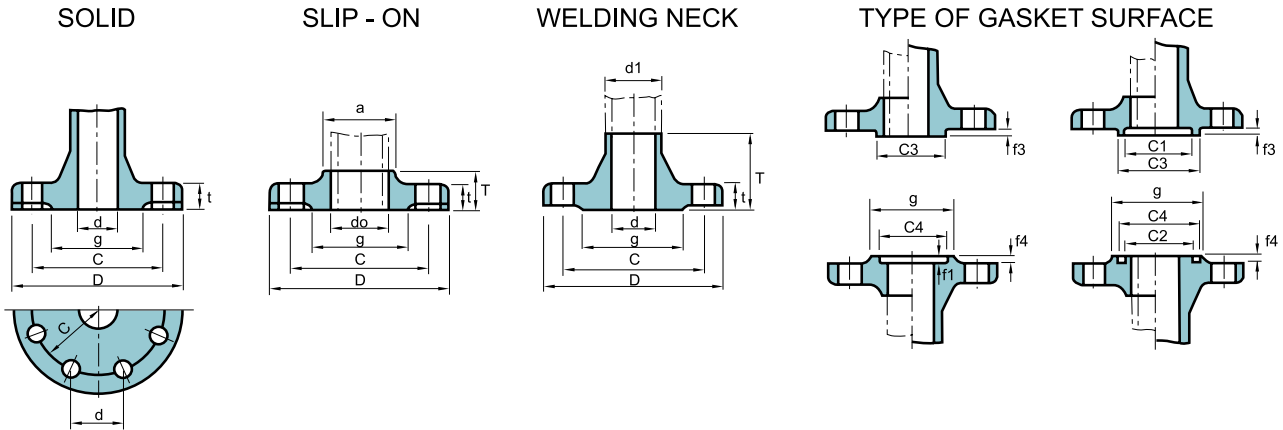

Flange Section		Surface Condition	Basic Size	Dimensional Tolerance
Outside Dia. D	As Forged (1)		300 & below	+not specified
			over 300 thru 600	-2.0
			over 600 thru 1000	+not specified
			over 1000 thru 1500	-3.0
			over 1500	
	Finish		300 & below	±1
over 300 thru 600			±1.5	
over 600 thru 1000			±2	
over 1000 thru 1500			±2.5	
Inside Dia.	Solid Flange d(2)	As Forged (1)	16 & below	±1
			over 16 thru 63	±1.5
			over 63 thru 125	±2
			over 125 thru 150	±2.5
			over 250 thru 500	±3
	Slip-on Flange do	Finish	100 & below	+0.5, 0
			over 100 thru 400	+1, 0
			over 400 thru 600	+1.5, 0
			over 600 thru 800	+2.0, 0
			over 800 thru 1000	+2.5, 0
			over 1000	+3, 0
	Welding Neck Flange d	Finish	100 & below	0, -0.5
			over 100 thru 400	0, -1
			over 400 thru 600	0, -1.5
			over 600 thru 800	0, -2
			over 800 thru 1000	0, -2.5
Bolt Hole	Bolt Circle Dia. c		250 & below	±0.5
			over 250 thru 550	±0.6
			over 550 thru 950	±0.8
			over 950 thru 1350	±1
			over 1350	±1.5

Flange Section		Surface Condition	Basic Size	Dimensional Tolerance
Bolt Hole	Pitch of Hole P	Drilling Hole		±0.5
Dia. of Hub	Slip-on Flange (a) and Welding Neck Flange (d1)	As Forged (1)	220 & below	+2, 0
			over 220 thru 450	+3, 0
			over 450 thru 650	+4, 0
			over 650 thru 850	+6, 0
			over 850 thru 1000	+7, 0
	Finish	220 & below	+1, 0	
		over 220 thru 450	+1.5, 0	
		over 450 thru 650	+2, 0	
		over 650 thru 850	+2.5, 0	
		over 850 thru 1000	+3, 0	
Gasket Seat	C1, C2, C3, C4	Finish	500 & below	±0.3
			over 500 thru 1000	±0.35
			over 1000 thru 1500	±0.4
	f3, f4	Finish	over 1500	±0.5
			8 & below	±0.2
			over 8	±0.25
Thickness	g	Finish	200 & below	±0.8
			over 200 thru 650	±0.9
			over 650 thru 1000	±1
	One-side Finish	over 1000	±1.2	
		20 & below	+1.5, 0	
		over 20 thru 50	+2, 0	
Bolt-side Finish	over 50 thru 100	+3, 0		
	20 & below	+1, 0		
	over 20 thru 50	+1.5, 0		
Hub Height T	Flange with pipe Inserted	Finish	over 50 thru 100	±2, 0
			over 100 thru 200	±2
	Flange with Butt-Welded Pipe	Finish	over 200 & below	+2, 0
			over 200 thru 300	+3, 0

### Notes

1. This dimensional tolerance applies to the machined surface, as required.
2. This dimension d has been specified only for the flange, of which the bore part is cylindrical in shape.

### Remarks

1. The dimensions d of bore part of the solid flanges with surface, as forged of valves, pumps, etc. are allowed up to plus 100% of the above dimensional tolerance. Provided that the required thickness shall be free from its influence.
2. The thickness of flange of valve and the like, of which the dimension between flange faces is limited to a fixed value, are allowed up to plus 100% of the above dimensional tolerance in the column of thickness.
3. In the case of spot facing of the single surface finishing, the thickness of spot facing is allowed up to 70% of the dimensional tolerance in the above column of thickness in negative side.
4. The chain double-lines in the figures of solid flange and socket welding type flange illustrate the cases of large raised face flange.

# WELDING ENDS

## ANSI B16.5 Forged Flanges

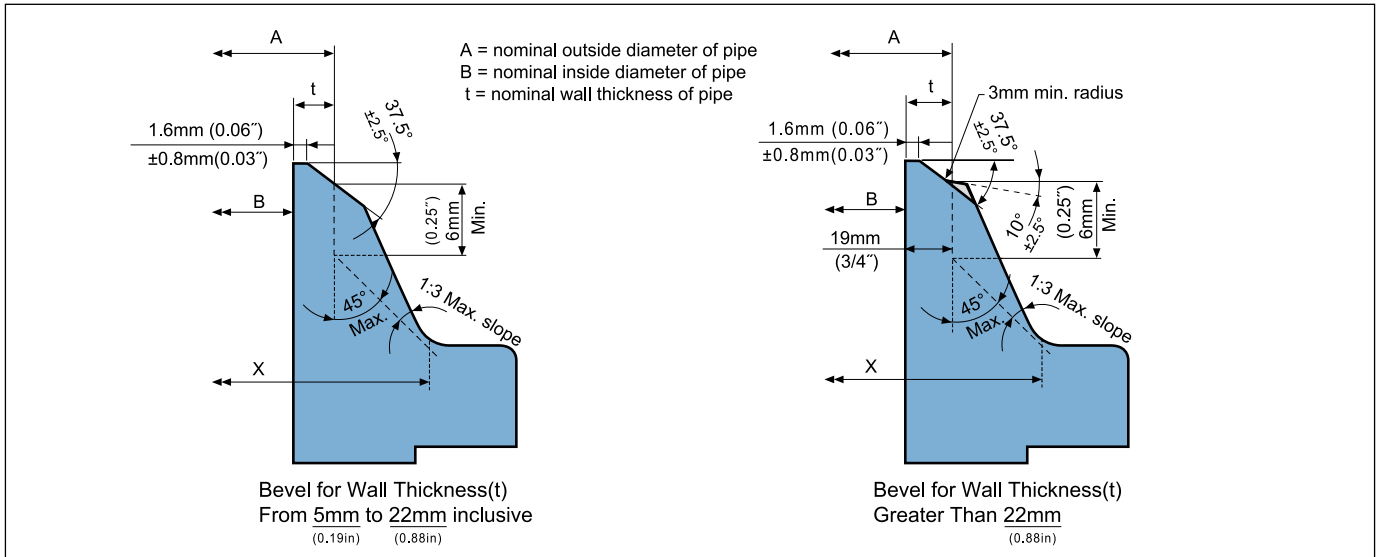

**Notes :**

When the thickness of the hub at the bevel is greater than that of the pipe to which the flange is joined and the additional thickness is provided on the outside diameter, a taper weld having a slop not exceeding 1 to 3 may be employed or, alternatively, the greater outside diameter may be tapered, at the same maximum slope or less, from a point on the welding bevel equal th the O.D. at the mating pipe. Similarly, when the greater thickness is provided on the inside of the flange, it shall be taper-bored from the welding end at a slope not exceeding 1 to 3

When flanges covered by this standard are intended for services with light wall, higher strength pipe, the thickness of the hub at the bevel may be greater than that of the pipe to which the flange is joined. Under these conditions a single taper hub may be provided and the outside diameter of the hub at the base (Dimension X) may also be modified.

The additional thickness may be provided on either inside or outside or partially on each side, but the total additional thickness shall not exceed on-half times the nominal wall thickness of intended mating pipe

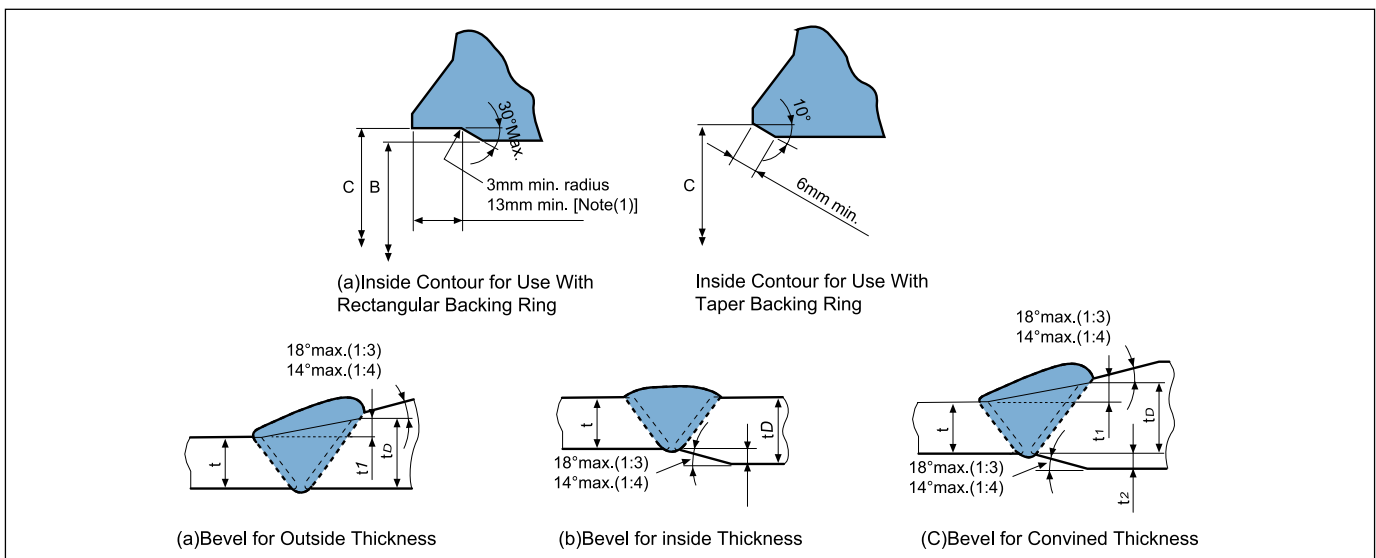

**Notes :**

- (1) When the materials joined have equal minimum specified yield strength, there shall be no restriction on the minimum slope.
- (2) Neither t1, t2, t3 nor their sum (t1 + t2) shall exceed 0.5t
- (3) When the minimum specified yield strengths of the sections to be joined are unequal, the value of to shall at least equal t time the ratio of minimum specified yield strength of the pipe to minimum specified yield strength of the flange.



# ANSI FLANGES

- Class 150 Flanges
- Class 300 Flanges
- Class 400 Flanges
- Class 600 Flanges
- Class 900 Flanges
- Class 1500 Flanges
- Class 2500 Flanges



## CLASS 150 FLANGES

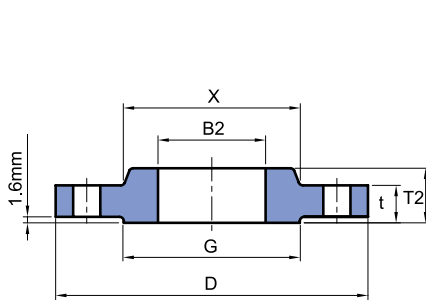

SLIP-ON

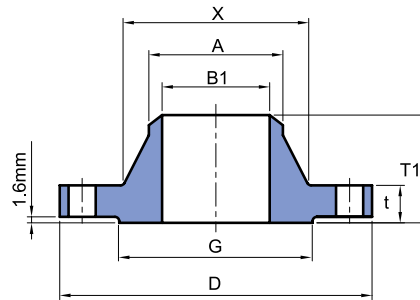

WELDING NECK

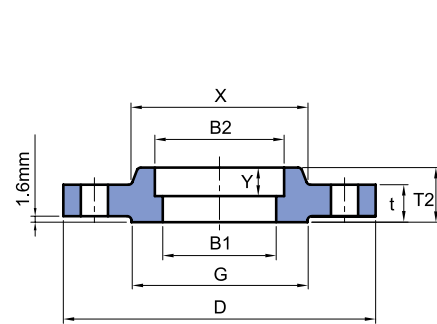

SOCKET WELDING

## ANSI B 16.5 Forged Flanges

Unit : mm

Nominal Pipe Size	Outside Diam.	Diam. at Base of Hub	O.D of Raised Face	Thickness	BORE			LENGTH THRU HUB			Diam. of Hub at Bevel	Radius of Fillet	Thread Length	Depth of Socket
					Welding Neck Socket Welding	Slip-on Socket Welding	Lap Joint	Welding Neck	Slip-on Threaded Socket Welding	Lap Joint				
					B1	B2	B3	T1	T2	T3				
1/2	89	30.2	35.1	11.2	15.8	22.4	22.9	47.8	15.7	15.7	21.3	3.0	15.7	9.7
3/4	99	38.1	42.9	12.7	20.8	27.7	28.2	52.3	15.7	15.7	26.7	3.0	15.7	11.2
1	108	49.3	50.8	14.2	26.7	34.5	35.1	55.6	17.5	17.5	33.5	3.0	17.5	12.7
1 1/4	117	58.7	63.5	15.7	35.1	43.2	43.7	57.2	20.6	20.6	42.2	4.8	20.6	14.2
1 1/2	127	65.0	73.2	17.5	40.9	49.5	50.0	62.0	22.4	22.4	48.3	6.4	22.4	15.8
2	152	77.7	91.9	19.1	52.6	62.0	62.5	63.5	25.4	25.4	60.5	7.9	25.4	17.5
2 1/2	178	90.4	104.6	22.4	62.7	74.7	75.4	69.9	28.4	28.4	73.2	7.9	28.4	19.1
3	191	108.0	127.0	23.9	78.0	90.7	91.4	69.9	30.2	30.2	88.9	9.7	30.2	20.6
3 1/2	216	122.2	139.7	23.9	90.2	103.4	104.1	71.4	31.8	31.8	101.6	9.7	31.8	22.4
4	229	134.9	157.2	23.9	102.4	116.1	116.8	76.2	33.3	33.3	114.3	11.2	33.3	23.9
5	254	163.6	185.7	23.9	128.3	143.8	144.5	88.9	36.6	36.6	141.2	11.2	36.6	23.9
6	279	192.0	215.9	25.4	154.2	170.7	171.5	88.9	39.6	39.6	168.4	12.7	39.6	26.9
8	343	246.1	269.7	28.4	202.7	221.5	222.3	101.6	44.5	44.5	219.2	12.7	44.5	31.8
10	406	304.8	323.9	30.2	254.5	276.4	277.4	101.6	49.3	49.3	273.1	12.7	49.3	33.3
12	483	365.3	381.0	31.8	304.8	327.2	328.2	114.3	55.6	55.6	323.9	12.7	55.6	39.6
14	533	400.1	412.8	35.1	336.6	359.2	360.2	127.0	57.2	79.2	355.6	12.7	57.2	41.4
16	597	457.2	469.9	36.6	387.4	410.5	411.2	127.0	63.5	87.4	406.4	12.7	63.5	44.5
18	635	505.0	533.4	39.6	438.2	461.8	462.3	139.7	68.3	96.8	457.2	12.7	68.3	49.3
20	699	558.8	584.2	42.9	489.0	513.1	514.4	144.5	73.2	103.1	508.0	12.7	73.2	54.1
24	813	663.4	692.2	47.8	590.6	616.0	616.0	152.4	82.6	111.3	609.6	12.7	82.6	63.5

NOTE :

1. For the 'Bore' (B1) other Standard Wall Thickness.
2. Class 150 flanges except Lap Joint will be furnished with 0.06" (1.6mm) raised face, which is included in 'Thickness' (t) and 'Length through Hub' (T1), (T2).
3. For Slip-on, Threaded, Socket Welding and Lap Joint Flanges, the hubs can be shaped either vertical from base to top or tapered within the limits of 7 degrees.

# ANSI FLANGE

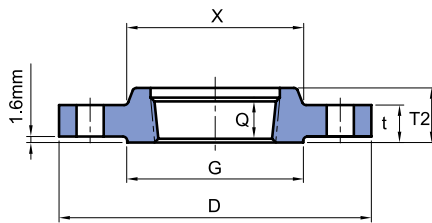

THREADED

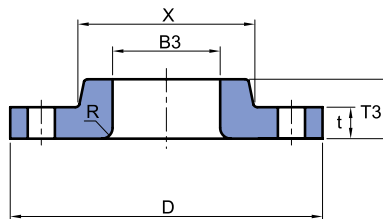

LAP JOINT

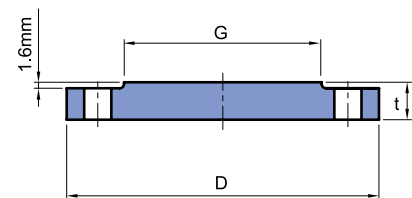

BLIND

Unit : mm

Nominal Pipe Size	DRILLING			BOLTING				APPROXIMATE WEIGHT									
	Bolt Circle Diam.	Number of Holes	Diam. of Holes	Diam. of Bolts (inch)	Machine Bolt Length		Stud Bolt Length	Welding Neck		Slip-on and Threaded		Lap Joint		Blind		Socket Welding	
					Raised Face	Ring Joint		Kg	lb	Kg	lb	Kg	lb	Kg	lb	Kg	lb
1/2	60.5	4	15.7	1/2	50.8	57.2	-	0.51	1.10	0.47	1.00	0.51	1.00	0.47	1.00	0.47	1.00
3/4	69.9	4	15.7	1/2	50.8	63.5	-	0.73	1.60	0.58	1.30	0.64	1.40	0.63	1.40	0.59	1.30
1	79.3	4	15.7	1/2	57.2	63.5	76.2	1.07	2.40	0.86	1.90	0.93	1.80	0.94	2.10	0.87	1.90
1 1/4	88.9	4	15.7	1/2	57.2	69.9	82.6	1.40	3.10	1.08	2.40	1.16	2.00	1.23	2.70	1.11	2.40
1 1/2	98.6	4	15.7	1/2	63.5	69.9	82.6	1.81	4.00	1.41	3.10	1.51	3.30	1.62	3.60	1.45	3.20
2	120.7	4	19.1	5/8	69.9	82.6	95.3	2.59	5.70	2.26	5.00	2.38	5.20	2.64	5.80	2.33	5.00
2 1/2	139.7	4	19.1	5/8	76.2	88.9	101.6	4.28	9.40	3.43	7.60	3.60	7.90	4.06	9.00	3.55	7.80
3	152.4	4	19.1	5/8	76.2	88.9	101.6	5.18	11.40	3.87	8.50	4.04	8.90	4.90	10.80	4.02	8.90
3 1/2	177.8	8	19.1	5/8	76.2	88.9	101.6	5.45	12.00	4.99	11.00	4.99	11.00	5.90	13.00	4.99	11.00
4	190.5	8	19.1	5/8	76.2	88.9	101.6	7.32	16.10	5.75	12.70	5.96	13.00	7.41	16.30	5.99	13.20
5	215.9	8	22.4	3/4	82.6	95.3	108.0	8.91	19.60	6.22	13.70	6.44	14.00	8.76	19.30	6.68	14.70
6	241.3	8	22.4	3/4	82.6	101.6	114.3	11.26	24.80	7.38	16.30	7.59	16.70	11.31	24.90	7.99	17.60
8	298.5	8	22.4	3/4	88.9	108.0	120.7	17.68	39.00	12.36	27.30	12.66	27.90	19.92	43.90	13.29	29.30
10	362.0	12	25.4	7/8	101.6	114.3	127.0	24.79	54.70	17.10	37.70	16.78	37.00	29.39	64.80	19.50	43.00
12	431.8	12	25.4	7/8	101.6	120.7	133.4	38.98	85.90	27.68	61.00	28.30	62.40	43.70	96.30	29.03	64.00
14	476.3	12	28.5	1	114.3	133.4	146.1	51.71	114.00	35.20	77.60	41.50	91.50	59.42	140.00	38.56	85.00
16	539.8	16	28.5	1	114.3	133.4	146.1	64.41	142.00	42.18	93.00	52.98	116.80	77.11	170.00	44.49	98.00
18	577.9	16	31.8	1 1/8	127.0	146.1	158.8	74.84	165.00	49.71	109.60	59.00	130.00	94.80	209.00	54.43	120.00
20	635.0	20	31.8	1 1/8	139.7	158.8	171.5	89.36	197.00	65.50	140.00	72.12	159.00	123.38	272.00	70.31	155.00
24	749.3	20	35.1	1 1/4	152.4	171.5	184.2	119.66	263.80	90.50	199.50	99.02	218.30	188.24	415.00	95.25	210.00

- Blind Flanges may be made with the same hub as that used for Slip-on Flanges or without hub.
- The gasket surface and backside (bearing surface for bolting) are made parallel within 1 degree. To accomplish parallelism, spot facing is carried out according to MSS SP-9, without reducing thickness (t).
- Depth of Socket (Y) is covered by ANSI B 16.5 only in sizes through 3 inch, over 3 inch is at the manufacturer's option.

## CLASS 300 FLANGES

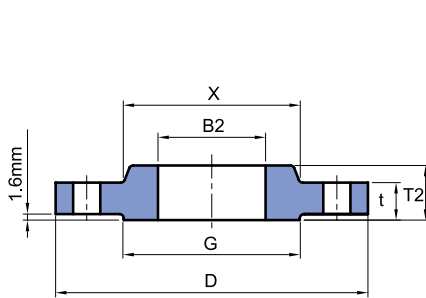

SLIP-ON

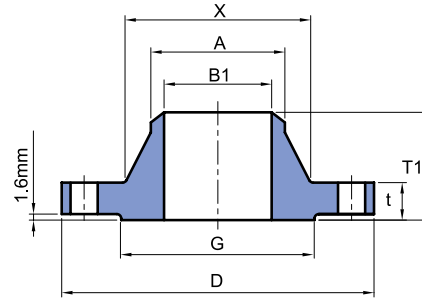

WELDING NECK

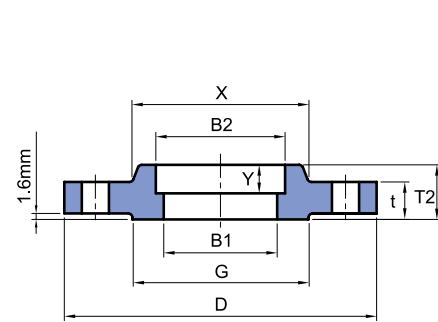

SOCKET WELDING

## ANSI B 16.5 Forged Flanges

Unit : mm

Nominal Pipe Size	Outside Diam.	Diam. at Base of Hub	O.D of Raised Face	Thickness	BORE				LENGTH THRU HUB			Diam. of Hub at Bevel	Radius of Fillet	Thread Length	Depth of Socket
					Welding Neck Socket Welding	Slip-on Socket Welding	Lap Joint	Counter Bore Min.	Welding Neck	Slip-on Threaded Socket Welding	Lap Joint				
	D	X	G	t	B1	B2	B3	B	T1	T2	T3	A	R	Q	Y
1/2	95	38.1	35.1	14.2	15.7	22.4	22.9	23.6	52.3	22.4	22.4	21.3	3.0	15.7	9.7
3/4	117	47.8	42.9	15.7	20.8	27.7	28.2	29.0	57.2	25.4	25.4	26.7	3.0	15.7	11.2
1	124	53.8	50.8	17.5	26.7	34.5	35.1	35.8	62.0	26.9	26.9	33.5	3.0	17.5	12.7
1 1/4	133	63.5	63.5	19.1	35.1	43.2	43.7	44.5	65.0	26.9	26.9	42.2	4.8	20.6	14.2
1 1/2	155	69.9	73.2	20.6	40.9	49.5	50.0	50.5	68.3	30.2	30.2	48.3	6.4	22.4	15.7
2	165	84.1	91.9	22.4	52.6	62.0	62.5	63.5	69.9	33.3	33.3	60.5	7.9	28.4	17.5
2 1/2	191	100.1	104.6	25.4	62.7	74.7	75.4	76.2	76.2	38.1	38.1	73.2	7.9	31.8	19.1
3	210	117.3	127.0	28.4	78.0	90.7	91.4	92.2	79.2	42.9	42.9	88.9	9.7	31.8	20.6
3 1/2	229	133.4	139.7	30.2	90.2	103.4	104.1	104.9	81.0	44.5	44.5	101.6	9.7	36.6	22.4
4	254	146.1	157.2	31.8	102.4	116.1	116.8	117.6	85.9	47.8	47.8	114.3	11.2	36.6	23.9
5	279	177.8	185.7	35.1	128.3	143.8	144.5	144.5	98.6	50.8	50.8	141.2	11.2	42.9	23.9
6	318	206.2	215.9	36.6	154.2	170.7	171.5	171.5	98.6	52.3	52.3	168.4	12.7	46.0	26.9
8	381	260.4	269.7	41.1	202.7	221.5	222.3	222.3	111.3	62.0	62.0	219.2	12.7	50.8	31.8
10	445	320.5	323.9	47.8	254.5	276.4	277.4	276.4	117.3	66.5	95.3	273.1	12.7	55.6	33.3
12	521	374.7	381.0	50.8	304.8	327.2	328.2	328.7	130.0	73.2	101.6	323.9	12.7	60.5	39.6
14	584	425.5	412.8	53.8	336.6	359.2	360.2	360.4	142.7	76.2	111.3	355.6	12.7	63.5	41.4
16	648	482.6	469.9	57.2	387.4	410.5	411.2	411.2	146.1	82.6	120.7	406.4	12.7	68.3	44.5
18	711	533.4	533.4	60.5	438.2	461.8	462.3	462.0	158.8	88.9	130.0	457.2	12.7	69.9	49.3
20	775	587.2	584.2	63.5	489.0	513.1	514.4	512.8	162.1	95.3	139.7	508.0	12.7	73.2	54.1
24	914	701.5	692.2	69.9	590.6	616.0	616.0	614.4	168.1	106.4	152.4	609.6	12.7	82.6	63.5

NOTE :

1. For the 'Bore' (B1) other Standard Wall Thickness,
2. Class 300 flanges except Lap Joint will be furnished with 0.06" (1.6mm) raised face, which is included in 'Thickness' (t) and 'Length through Hub' (T1), (T2).
3. For Slip-on, Threaded, Socket Welding and Lap Joint Flanges, the hubs can be shaped either vertical from base to top or tapered within the limits of 7 degrees.



# ANSI FLANGE

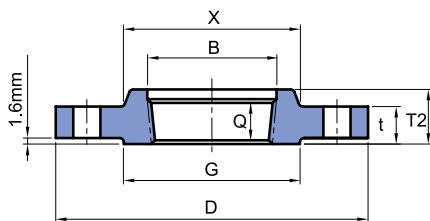

THREADED

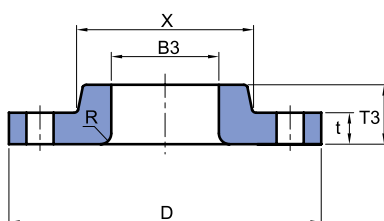

LAP JOINT

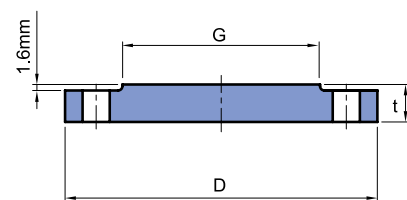

BLIND

Unit : mm

Nominal Pipe Size	DRILLING			BOLTING			APPROXIMATE WEIGHT										
	Bolt Circle Diam.	Number of Holes	Diam. of Holes	Diam. of Bolts (inch)	Machine Bolt Length		Stud Bolt Length	Welding Neck		Slip-on and Threaded		Lap Joint		Blind		Socket Welding	
					Raised Face	Ring Joint		Kg	lb	Kg	lb	Kg	lb	Kg	lb	Kg	lb
1/2	66.5	4	15.7	1/2	57.2	63.5	76.2	0.78	1.70	0.62	1.40	0.61	1.30	0.62	1.40	0.62	1.40
3/4	82.6	4	19.1	5/8	63.5	76.2	88.9	1.34	3.00	1.15	2.50	1.15	2.50	1.16	2.50	1.19	2.60
1	88.9	4	19.1	5/8	63.5	76.2	88.9	1.64	3.60	1.39	3.10	1.38	3.00	1.42	3.00	1.44	3.20
1 1/4	98.6	4	19.1	5/8	69.9	82.6	95.3	2.06	4.50	1.67	3.70	1.66	3.70	1.79	3.90	1.73	3.80
1 1/2	114.3	4	22.4	3/4	76.2	88.9	101.6	3.06	6.70	2.53	5.60	2.52	5.60	2.68	5.90	2.62	5.80
2	127.0	8	19.1	5/8	76.2	88.9	101.6	3.40	7.50	2.80	6.20	2.79	6.20	3.09	6.80	2.94	6.50
2 1/2	149.4	8	22.4	3/4	82.6	101.6	114.3	5.31	11.70	4.25	9.40	4.22	9.30	4.75	10.50	4.49	9.90
3	168.1	8	22.4	3/4	88.9	108.0	120.7	7.32	16.10	5.81	12.80	5.78	12.70	6.79	14.90	6.20	13.70
3 1/2	184.2	8	22.4	3/4	95.3	108.0	127.0	8.17	18.00	7.72	17.00	7.72	17.00	9.53	21.00	-	-
4	200.2	8	22.4	3/4	95.3	114.3	127.0	11.30	24.90	10.13	22.30	10.07	22.20	12.00	26.50	-	-
5	235.0	8	22.4	3/4	108.0	120.7	133.4	15.12	33.30	12.58	27.70	12.52	27.60	15.96	35.20	-	-
6	269.7	12	22.4	3/4	108.0	120.7	139.7	19.68	43.40	16.04	35.40	15.95	35.20	21.20	46.70	-	-
8	330.2	12	25.4	7/8	120.7	139.7	152.4	30.48	67.20	24.50	54.00	24.37	53.70	34.60	76.30	-	-
10	387.4	16	28.4	1	139.7	158.8	171.5	43.74	96.40	34.16	75.30	39.92	88.00	55.34	122.00	-	-
12	450.9	16	31.8	1 1/8	146.1	171.5	184.2	64.41	142.00	51.26	113.00	58.70	129.40	78.90	174.00	-	-
14	514.4	20	31.8	1 1/8	158.8	177.8	190.5	88.30	194.70	72.12	159.00	83.46	184.00	107.05	236.00	-	-
16	571.5	20	35.1	1 1/4	165.1	190.5	203.2	112.94	249.00	90.40	199.30	106.14	234.00	139.25	307.00	-	-
18	628.7	24	35.1	1 1/4	171.5	196.9	209.6	138.34	305.00	109.00	240.30	133.95	295.30	176.90	396.00	-	-
20	685.8	24	35.1	1 1/4	184.2	203.2	222.3	167.37	369.00	136.00	300.00	157.65	347.60	223.17	492.00	-	-
24	812.8	24	41.1	1 1/2	203.2	228.6	254.0	235.41	519.00	204.00	449.70	240.40	530.00	342.00	754.00	-	-

- Blind Flanges may be made with the same hub as that used for Slip-on Flanges or without hub.
- The gasket surface and backside (bearing surface for bolting) are made parallel within 1 degree. To accomplish parallelism, spot facing is carried out according to MSS SP-9, without reducing thickness (t).
- Depth of Socket (Y) is covered by ANSI B 16.5 only in sizes through 3 inch, over 3 inch is at the manufacturer's option.

## CLASS 400 FLANGES

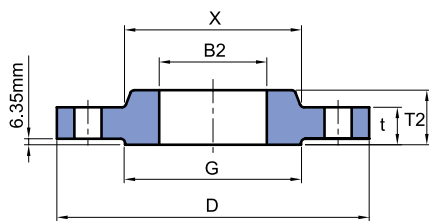

SLIP-ON

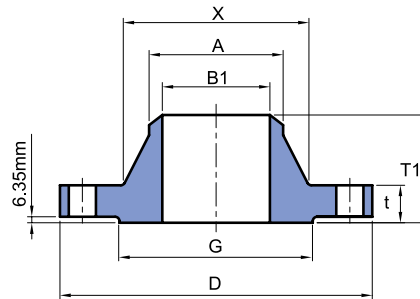

WELDING NECK

## ANSI B 16.5 Forged Flanges

Unit : mm

Nominal Pipe Size	Outside Diam.	Diam. at Base of Hub	O.D of Raised Face	Thickness	BORE				LENGTH THRU HUB			Diam. of Hub at Bevel	Radius of Fillet	Thread Length	
					Welding Neck	Slip-on	Lap Joint	Counter Bore Min.	Welding Neck	Slip-on Threaded	Lap Joint				
															B1
1/2	95	38.1	35.1	14.2	See Note (1) To be specified by purchaser.		22.4	22.9	23.6	52.3	22.4	22.4	21.3	3.0	15.7
3/4	117	47.8	42.9	15.7			27.7	28.2	29.0	57.2	25.4	25.4	26.7	3.0	15.7
1	124	53.8	50.8	17.5			34.5	35.1	35.8	62.0	26.9	26.9	33.5	3.0	17.5
1 1/4	133	63.5	63.5	20.6			43.2	43.7	44.5	66.5	28.4	28.4	42.2	4.8	20.6
1 1/2	155	69.9	73.2	22.4			49.5	50.0	50.5	69.9	31.8	31.8	48.3	6.4	22.4
2	165	84.1	91.9	25.4			62.0	62.5	63.5	73.2	36.6	36.6	60.5	7.9	28.4
2 1/2	191	100.1	104.6	28.4			74.7	75.4	76.2	79.2	41.1	41.1	73.2	7.9	31.8
3	210	117.3	127.0	31.8			90.7	91.4	92.2	82.6	46.0	46.0	88.9	9.7	35.1
3 1/2	229	133.4	139.7	35.1			103.4	104.1	104.9	85.9	49.3	49.3	101.6	9.7	39.6
4	254	146.1	157.2	35.1			116.1	116.8	117.6	88.9	50.8	50.8	114.3	11.2	36.6
5	279	177.8	185.7	38.1			143.8	144.5	144.5	101.6	53.8	53.8	141.2	11.2	42.9
6	318	206.2	215.9	41.1			170.7	171.5	171.5	103.1	57.2	57.2	168.4	12.7	46.0
8	381	260.4	269.7	47.8			221.5	222.3	222.3	117.3	68.3	68.3	219.2	12.7	50.8
10	445	320.5	323.9	53.8			276.4	277.4	276.4	124.0	73.2	101.6	273.1	12.7	55.6
12	521	374.7	381.0	57.2			327.2	328.2	328.7	136.7	79.2	108.0	323.9	12.7	60.5
14	584	425.5	412.8	60.5			359.2	360.2	360.4	149.4	84.1	117.3	355.6	12.7	63.5
16	648	482.6	469.9	63.5		410.5	411.2	411.2	152.4	93.7	127.0	406.4	12.7	68.3	
18	711	533.4	533.4	66.5		461.8	462.3	462.0	165.1	98.6	136.7	457.2	12.7	69.9	
20	775	587.2	584.2	69.9		513.1	514.4	512.8	168.1	101.6	146.1	508.0	12.7	73.2	
24	914	701.5	692.2	76.2		616.0	616.0	614.4	174.8	114.3	158.8	609.6	12.7	82.6	

NOTE :

1. For the 'Bore' (B1) other Standard Wall Thickness,
2. Class 400 flanges except Lap Joint will be furnished with 0.25" (6.35mm) raised face, which is included in 'Thickness' (t) and 'Length through Hub' (T1), (T2).
3. For Slip-on, Threaded, Socket Welding and Lap Joint Flanges, the hubs can be shaped either vertical from base to top or tapered within the limits of 7 degrees.

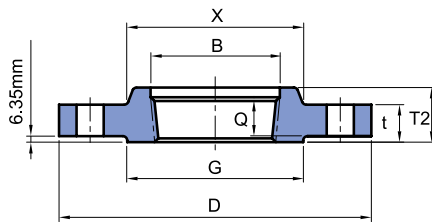

THREADED

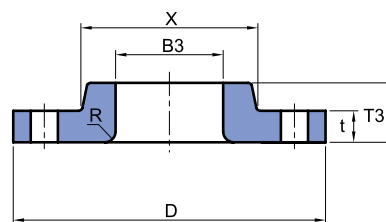

LAP JOINT

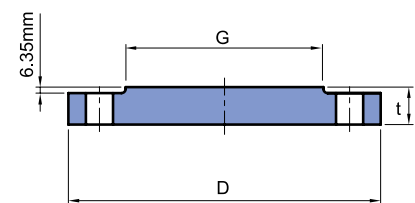

BLIND

Unit : mm

Nominal Pipe Size	DRILLING			BOLTING				APPROXIMATE WEIGHT							
	Bolt Circle Diam.	Number of Holes	Diam. of Holes	Diam. of Bolts (inch)	Stud Bolt Length			Welding Neck		Slip-on and Threaded		Lap Joint		Blind	
					0.25" Raised Face	Male-Female Tongue-Groove	Ring Joint								
Kg	lb	Kg	lb	Kg	lb	Kg	lb	Kg	lb						
1/2	66.5	4	15.7	1/2	76.2	69.9	76.2	1.36	3.00	0.91	2.00	0.80	1.80	0.91	2.00
3/4	82.6	4	19.1	5/8	88.9	82.6	88.9	1.59	3.50	1.36	3.00	1.36	3.00	1.40	3.00
1	88.9	4	19.1	5/8	88.9	82.6	88.9	1.81	4.00	1.59	3.50	1.59	3.50	1.70	3.80
1 1/4	98.6	4	19.1	5/8	95.3	88.9	95.3	2.50	5.50	2.10	4.60	2.04	4.50	2.27	5.00
1 1/2	114.3	4	22.4	3/4	108.0	101.6	108.0	3.63	8.00	3.10	6.80	2.95	6.50	3.40	7.50
2	127.0	8	19.1	5/8	108.0	101.6	108.0	4.54	10.00	3.63	8.00	3.63	8.00	4.40	9.70
2 1/2	149.4	8	22.4	3/4	120.7	114.3	120.7	6.35	14.00	5.44	12.00	4.99	11.00	6.80	15.00
3	168.1	8	22.4	3/4	127.0	120.7	127.0	8.17	18.00	7.26	16.00	6.35	14.00	8.90	19.60
3 1/2	184.2	8	25.4	7/8	139.7	133.4	139.7	11.80	26.00	9.53	21.00	9.08	20.00	13.17	29.00
4	200.2	8	25.4	7/8	139.7	133.4	139.7	13.61	30.00	10.89	24.00	9.98	22.00	14.40	31.70
5	235.0	8	25.4	7/8	146.1	139.7	146.1	17.69	39.00	14.07	31.00	13.15	29.00	19.50	43.00
6	269.7	12	25.4	7/8	152.4	146.1	152.4	22.23	49.00	19.98	44.00	16.78	37.00	27.67	61.00
8	330.2	12	28.4	1	171.5	165.1	171.5	35.38	78.00	30.40	67.00	26.16	59.00	45.36	100.00
10	387.4	16	31.8	1 1/8	190.5	184.2	190.5	49.89	110.00	41.28	91.00	43.09	95.00	68.00	150.00
12	450.9	16	35.1	1 1/4	203.2	196.9	203.2	72.57	160.00	59.02	130.00	68.95	152.00	98.00	216.00
14	514.4	20	35.1	1 1/4	209.6	203.2	209.6	105.69	233.00	81.72	180.00	95.25	210.00	131.66	290.00
16	571.5	20	38.1	1 3/8	222.3	215.9	222.3	133.30	294.00	106.69	235.00	127.00	280.00	167.00	368.00
18	628.7	24	38.1	1 3/8	228.6	222.3	228.6	158.90	350.30	129.39	285.30	156.49	345.00	206.57	455.40
20	685.8	24	41.1	1 1/2	241.3	235.0	247.7	193.00	425.50	152.00	335.00	190.51	420.00	261.00	575.40
24	812.8	24	47.8	1 3/4	266.7	260.4	279.4	281.48	620.50	231.54	510.50	278.96	615.00	395.00	870.80

4. Blind Flanges may be made with the same hub as that used for Slip-on Flanges or without hub.
5. The gasket surface and backside (bearing surface for bolting) are made parallel within 1 degree. To accomplish parallelism, spot facing is carried out according to MSS SP-9, without reducing thickness (t).
6. Dimensions of size 1/2" through 3 1/2" are the same as for Class 600 Flanges.



## CLASS 600 FLANGES

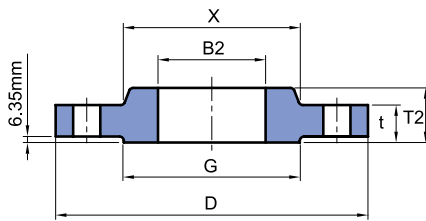

SLIP-ON

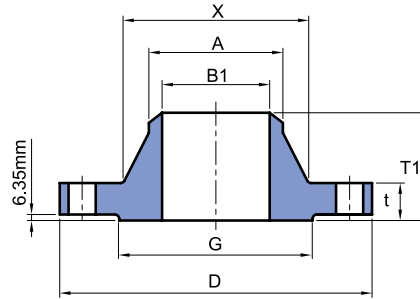

WELDING NECK

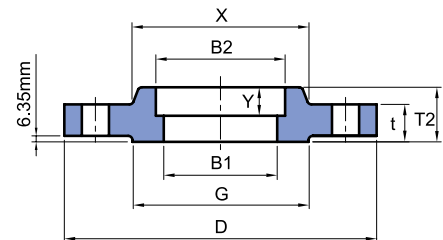

SOCKET WELDING

## ANSI B 16.5 Forged Flanges

Unit : mm

Nominal Pipe Size	Outside Diam.	Diam. at Base of Hub	O.D. of Raised Face	Thickness	BORE				LENGTH THRU HUB			Diam. of Hub at Bevel	Radius of Fillet	Thread Length	Depth of Socket
					Welding Neck Socket Welding	Slip-on Socket Welding	Lap Joint	Counter Bore Min.	Welding Neck	Slip-on Threaded Socket Welding	Lap Joint				
					B1	B2	B3	B	T1	T2	T3				
1/2	95	38.1	35.1	14.2	See Note (1) To be specified by purchaser.	22.4	22.9	23.6	52.3	22.4	22.4	21.3	3.0	15.7	9.7
3/4	117	47.8	42.9	15.7		27.7	28.2	29.0	57.2	25.4	25.4	26.7	3.0	15.7	11.2
1	124	53.8	50.8	17.5		34.5	35.1	35.8	62.0	26.9	26.9	33.5	3.0	17.5	12.7
1 1/4	133	63.5	63.5	20.6		43.2	43.7	44.5	66.5	28.4	28.4	42.2	4.8	20.6	14.2
1 1/2	155	69.9	73.2	22.4		49.5	50.0	50.5	69.9	31.8	31.8	48.3	6.4	22.4	15.7
2	165	84.1	91.9	25.4		62.0	62.5	63.5	73.2	36.6	36.6	60.5	7.9	28.4	17.5
2 1/2	191	100.1	104.6	28.4		74.7	75.4	76.2	79.2	41.1	41.1	73.2	7.9	31.8	19.1
3	210	117.3	127.0	31.8		90.7	91.4	92.2	82.6	46.0	46.0	88.9	9.7	35.1	20.6
3 1/2	229	133.4	139.7	35.1		103.4	104.1	104.9	85.9	49.3	49.3	101.6	9.7	39.6	22.4
4	273	152.4	157.2	38.1		116.1	116.8	117.6	101.6	53.8	53.8	114.3	11.2	41.1	23.9
5	330	189.0	185.7	44.5		143.8	144.5	144.5	114.3	60.5	60.5	141.2	11.2	47.8	23.9
6	356	222.3	215.9	47.8		170.7	171.5	171.5	117.3	66.5	66.5	168.4	12.7	50.8	26.9
8	419	273.1	269.7	55.6		221.5	222.3	222.3	133.4	76.2	76.2	219.2	12.7	57.2	31.8
10	508	342.9	323.9	63.5		276.4	277.4	276.4	152.4	85.9	111.3	273.1	12.7	65.0	33.3
12	559	400.1	381.0	66.5		327.2	328.2	328.7	155.4	91.9	117.3	323.9	12.7	69.9	39.6
14	603	431.8	412.8	69.9		359.2	360.2	360.4	165.1	93.7	127.0	355.6	12.7	73.2	41.4
16	686	495.3	469.9	76.2		410.5	411.2	411.2	177.8	106.4	139.7	406.4	12.7	77.7	44.5
18	743	546.1	533.4	82.6	461.8	462.3	462.0	184.2	117.3	152.4	457.2	12.7	79.2	49.3	
20	813	609.6	584.2	88.9	513.1	514.4	512.8	190.5	127.0	165.1	508.0	12.7	82.6	54.1	
24	940	717.6	692.2	101.6	616.0	616.0	614.4	203.2	139.7	184.2	609.6	12.7	91.9	63.5	

NOTE :

1. For the 'Bore' (B1) other Standard Wall Thickness,
2. Class 600 flanges except Lap Joint will be furnished with 0.25" (6.35mm) raised face, which is included in 'Thickness' (t) and 'Length through Hub' (T1), (T2).
3. For Slip-on, Threaded, Socket Welding and Lap Joint Flanges, the hubs can be shaped either vertical from base to top or tapered within the limits of 7 degrees.

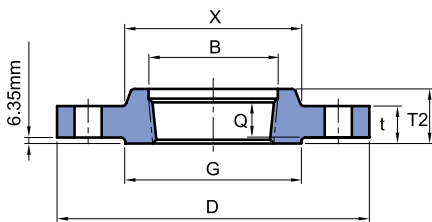

THREADED

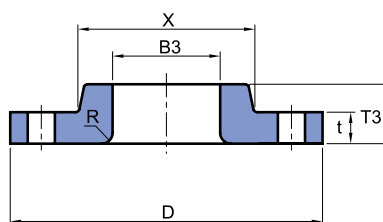

LAP JOINT

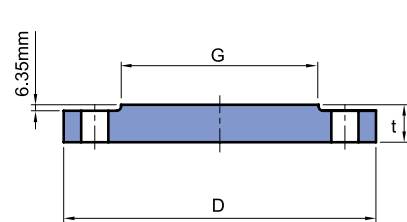

BLIND

Unit : mm

Nominal Pipe Size	DRILLING			BOLTING				APPROXIMATE WEIGHT									
	Bolt Circle Diam.	Number of Holes	Diam. of Holes	Diam. of Bolts (inch)	STUD BOLT LENGTH			Welding Neck		Slip-on and Threaded		Lap Joint		Blind		Socket Welding	
					0.25" Raised Face	Male - Female Tongue - Groove	Ring Joint	Kg	lb	Kg	lb	Kg	lb	Kg	lb	Kg	lb
1/2	66.5	4	15.7	1/2	76.2	69.9	76.2	0.90	2.00	0.91	2.00	0.80	1.80	0.91	2.00	0.91	2.00
3/4	82.6	4	19.1	5/8	88.9	82.6	88.9	1.59	3.50	1.40	3.00	1.36	3.00	1.40	3.00	1.36	3.00
1	88.9	4	19.1	5/8	88.9	82.6	88.9	1.90	4.00	1.70	3.70	1.59	3.50	1.81	4.00	1.81	4.00
1 1/4	98.6	4	19.1	5/8	95.3	88.9	95.3	2.49	5.50	2.27	5.00	2.04	4.50	2.40	5.30	2.60	5.70
1 1/2	114.3	4	22.4	3/4	108.0	101.6	108.0	3.63	8.00	3.10	6.80	2.95	6.50	3.40	7.50	3.18	7.00
2	127.0	8	19.1	5/8	108.0	101.6	108.0	4.54	10.00	3.63	8.00	3.63	8.00	4.40	9.70	3.90	8.60
2 1/2	149.4	8	22.4	3/4	120.7	114.3	120.7	6.35	14.00	5.44	12.00	4.99	11.00	6.80	15.00	5.90	13.00
3	168.1	8	22.4	3/4	127.0	120.7	127.0	8.16	18.00	7.26	16.00	6.35	14.00	8.90	19.60	7.40	16.30
3 1/2	184.2	8	25.4	7/8	139.7	133.4	139.7	11.80	26.00	9.53	21.00	9.08	20.00	13.17	29.00	-	-
4	215.9	8	25.4	7/8	146.1	139.7	146.1	16.78	37.00	14.97	33.00	14.06	31.00	18.60	41.00	-	-
5	266.7	8	28.4	1	165.1	158.8	165.1	30.87	68.00	28.50	62.80	27.50	60.60	30.84	68.00	-	-
6	292.1	12	28.4	1	171.5	165.1	171.5	36.77	80.00	36.32	80.00	35.38	78.00	38.00	83.80	-	-
8	349.3	12	31.8	1 1/8	190.5	184.2	196.9	50.80	112.00	44.00	97.00	50.80	112.00	62.20	137.00	-	-
10	431.8	16	35.1	1 1/4	215.9	209.6	215.9	86.26	190.00	76.20	168.00	74.00	163.00	102.00	224.90	-	-
12	489.0	20	35.1	1 1/4	222.3	215.9	222.3	102.51	226.00	97.52	215.00	108.86	240.00	132.00	291.00	-	-
14	527.1	20	38.1	1 3/8	235.0	228.6	235.0	121.56	268.00	102.00	224.80	111.00	244.70	158.00	348.30	-	-
16	603.3	20	41.1	1 1/2	254.0	247.7	254.0	177.06	290.00	149.82	330.20	165.71	365.30	224.73	495.40	-	-
18	654.1	20	44.5	1 5/8	273.1	266.7	273.1	215.65	475.40	180.10	412.30	194.00	427.70	285.00	628.30	-	-
20	723.9	24	44.5	1 5/8	285.8	279.4	292.1	267.86	590.50	231.54	510.50	258.78	570.50	365.00	804.70	-	-
24	838.2	24	50.8	1 7/8	330.2	323.9	336.6	372.00	820.00	330.00	725.50	362.00	798.00	533.45	1176.00	-	-

4. Blind Flanges may be made with the same hub as that used for Slip-on Flanges or without hub.
5. The gasket surface and backside (bearing surface for bolting) are made parallel within 1 degree. To accomplish parallelism, spot facing is carried out according to MSS SP-9, without reducing thickness (t).
- 6 Dimensions of sizes 1/2" through 3 1/2" are the same as for Class 400 Flanges.
7. Depth of Socket (Y) is covered by ANSI B 16.5 only in sizes through 3 inch, over 3 inch is at the manufacturer's option.

## CLASS 900 FLANGES

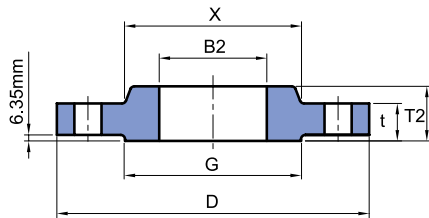

SLIP-ON

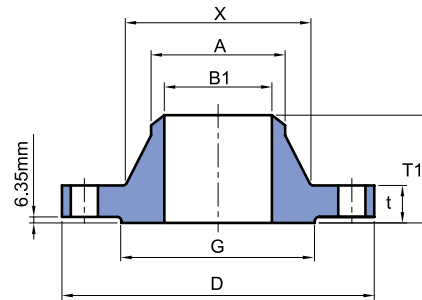

WELDING NECK

## ANSI B 16.5 Forged Flanges

Unit : mm

Nominal Pipe Size	Outside Diam.	Diam. at Base of Hub	O.D of Raised Face	Thickness	BORE				LENGTH THRU HUB			Diam. of Hub at Bevel	Radius of Fillet	Thread Length
					Welding Neck	Slip-on	Lap Joint	Counter Bore Min.	Welding Neck	Slip-on Threaded	Lap Joint			
					B1	B2	B3	B	T1	T2	T3			
1/2	121	38.1	35.1	22.4	See Note (1) To be specified by purchaser.	22.4	22.9	23.6	60.5	31.8	31.8	21.3	3.0	22.4
3/4	130	44.5	42.9	25.4		27.7	28.2	29.0	69.9	35.1	35.1	26.7	3.0	25.4
1	149	52.3	50.8	28.4		34.5	35.1	35.8	73.2	41.1	41.1	33.5	3.0	28.4
1 1/4	159	63.5	63.5	28.4		43.2	43.7	44.5	73.2	41.1	41.1	42.2	4.8	30.2
1 1/2	178	69.9	73.2	31.8		49.5	50.0	50.5	82.6	44.5	44.5	48.3	6.4	31.8
2	216	104.6	91.9	38.1		62.0	62.5	63.5	101.6	57.2	57.2	60.5	7.9	38.1
2 1/2	244	124.0	104.6	41.1		74.7	75.4	76.2	104.6	63.5	63.5	73.2	7.9	47.8
3	241	127.0	127.0	38.1		90.7	91.4	92.2	101.6	53.8	53.8	88.9	9.7	41.1
4	292	158.8	157.2	44.5		116.1	116.8	117.6	114.3	69.9	69.9	114.3	11.2	47.8
5	349	190.5	185.7	50.8		143.8	144.5	144.5	127.0	79.2	79.2	141.2	11.2	53.8
6	381	235.0	215.9	55.6		170.7	171.5	171.5	139.7	85.9	85.9	168.4	12.7	57.2
8	470	298.5	269.7	63.5		221.5	222.3	222.3	162.1	101.6	114.3	219.2	12.7	63.5
10	546	368.3	323.9	69.9		276.4	277.4	276.4	184.2	108.0	127.0	273.1	12.7	71.4
12	610	419.1	381.0	79.2		327.2	328.2	328.7	200.2	117.3	142.7	323.9	12.7	76.2
14	641	450.9	412.8	85.9		359.2	360.2	360.4	212.9	130.0	155.4	355.6	12.7	82.6
16	705	508.0	469.9	88.9		410.5	411.2	411.2	215.9	133.4	165.1	406.4	12.7	85.9
18	787	565.2	533.4	101.6		461.8	462.3	462.0	228.6	152.4	190.5	457.2	12.7	88.9
20	857	622.3	584.2	108.0		513.1	514.4	512.8	247.7	158.8	209.6	508.0	12.7	91.9
24	1041	749.3	692.2	139.7		616.0	616.0	614.4	292.1	203.2	266.7	609.6	12.7	101.6

NOTE :

1. For the 'Bore' (B1) other Standard Wall Thickness, |
2. Class 900 flanges except Lap Joint will be furnished with 0.25" (6.35mm) raised face, which is included in 'Thickness' (t) and 'Length through Hub' (T1), (T2).
3. For Slip-on, Threaded, Socket Welding and Lap Joint Flanges, the hubs can be shaped either vertical from base to top or tapered within the limits of 7 degrees.

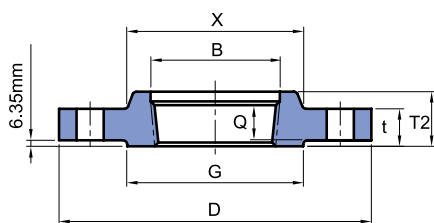

THREADED

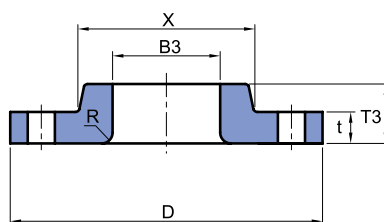

LAP JOINT

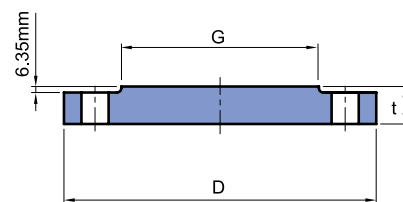

BLIND

Unit : mm

Nominal Pipe Size	DRILLING			BOLTING				APPROXIMATE WEIGHT							
	Bolt Circle Diam.	Number of Holes	Diam. of Holes	Diam. of Bolts (inch)	STUD BOLT LENGTH			Welding Neck		Slip-on and Threaded		Lap Joint		Blind	
					0.25" Raised Face	Male - Female Tongue - Groove	Ring Joint	Kg	lb	Kg	lb	Kg	lb	Kg	lb
1/2	82.6	4	22.4	3/4	108.0	101.6	108.0	2.10	4.60	1.81	4.00	1.81	4.00	1.90	4.20
3/4	88.9	4	22.4	3/4	114.3	108.0	114.3	2.72	6.00	2.40	5.30	2.30	5.00	2.70	6.00
1	101.6	4	25.4	7/8	127.0	120.7	127.0	3.86	8.50	3.41	7.50	3.40	7.50	4.09	9.00
1 1/4	111.3	4	25.4	7/8	127.0	120.7	127.0	4.54	10.00	4.10	9.00	4.09	9.00	4.54	10.00
1 1/2	124.0	4	28.4	1	139.7	133.4	139.7	5.90	13.00	5.45	12.00	5.40	11.90	5.90	13.00
2	165.1	8	25.4	7/8	146.1	139.7	146.1	10.89	24.00	9.98	22.00	9.53	21.00	11.34	25.00
2 1/2	190.5	8	28.4	1	158.8	152.4	158.8	16.33	36.00	15.80	34.80	13.15	29.00	16.00	35.30
3	190.5	8	25.4	7/8	146.1	139.7	146.1	15.00	33.00	11.80	26.00	11.34	25.00	13.17	29.00
4	235.0	8	31.8	1 1/8	171.5	165.1	171.5	23.13	51.00	23.20	51.00	22.60	48.50	24.50	54.00
5	279.4	8	35.1	1 1/4	190.5	184.2	190.5	38.50	84.90	37.65	83.00	36.74	81.00	39.46	87.00
6	317.5	12	31.8	1 1/8	190.5	184.2	196.9	49.89	110.00	48.30	106.50	47.50	104.70	51.50	113.50
8	393.7	12	38.1	1 3/8	222.3	215.9	222.3	79.45	175.00	75.00	166.30	86.00	189.60	89.00	106.20
10	469.9	16	38.1	1 3/8	235.0	228.6	235.0	118.04	260.00	111.13	245.00	125.64	277.00	131.54	290.00
12	533.4	20	38.1	1 3/8	254.0	247.7	254.0	157.00	346.00	146.00	321.80	167.00	368.00	187.00	412.30
14	558.8	20	41.1	1 1/2	273.1	266.7	279.4	181.60	400.40	172.36	380.00	180.07	397.00	224.07	494.00
16	616.0	20	44.5	1 5/8	285.8	279.4	292.1	224.73	495.50	192.95	425.40	211.11	465.40	272.40	600.50
18	685.8	20	50.8	1 7/8	323.9	317.5	336.6	308.72	680.60	272.40	600.50	295.10	650.60	385.90	850.80
20	749.3	20	53.8	2	349.3	342.9	362.0	376.82	830.70	331.42	730.60	367.74	810.70	488.00	1076.00
24	901.7	20	66.5	2 1/2	438.2	431.8	457.2	685.00	1510.00	632.00	1393.30	700.00	1543.00	905.00	1995.00

- Blind Flanges may be made with the same hub as that used for Slip-on Flanges or without hub.
- The gasket surface and backside (bearing surface for bolting) are made parallel within 1 degree. To accomplish parallelism, spot facing is carried out according to MSS SP-9, without reducing thickness (t).
- Dimensions of size 1/2" through 2 1/2" are the same as for Class 1500 Flanges.

## CLASS 1500 FLANGES

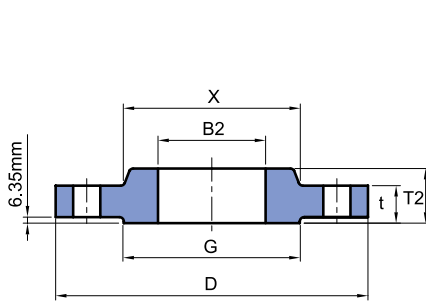

SLIP-ON

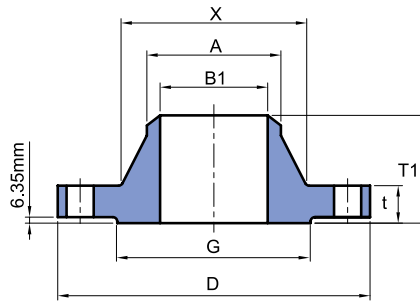

WELDING NECK

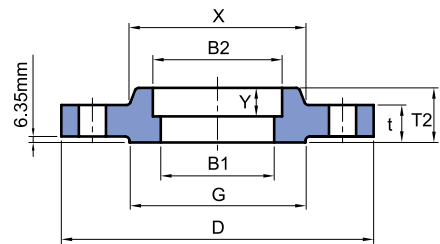

SOCKET WELDING

## ANSI B 16.5 Forged Flanges

Unit : mm

Nominal Pipe Size	Outside Diam.	Diam. at Base of Hub	O.D of Raised Face	Thickness	BORE				LENGTH THRU HUB			Diam. of Hub at Bevel	Radius of Fillet	Thread Length	Depth of Socket
					Welding Neck Socket Welding	Slip-on Socket Welding	Lap Joint	Counter Bore Min.	Welding Neck	Slip-on Threaded Socket Welding	Lap Joint				
					B1	B2	B3	B	T1	T2	T3				
1/2	121	38.1	35.1	22.4	See Note (1) To be specified by purchaser.	22.4	22.9	23.6	60.5	31.8	31.8	21.3	3.0	22.4	9.7
3/4	130	44.5	42.9	25.4		27.7	28.2	29.0	69.9	35.1	35.1	26.7	3.0	25.4	11.2
1	149	52.3	50.8	28.4		34.5	35.1	35.8	73.2	41.1	41.1	33.5	3.0	28.4	12.7
1 1/4	159	63.5	63.5	28.4		43.2	43.7	44.5	73.2	41.1	41.1	42.2	4.8	30.2	14.2
1 1/2	178	69.9	73.2	31.8		49.5	50.0	50.5	82.6	44.5	44.5	48.3	6.4	31.8	15.7
2	216	104.6	91.9	38.1		62.0	62.5	63.5	101.6	57.2	57.2	60.5	7.9	38.1	17.5
2 1/2	244	124.0	104.6	41.1		74.7	75.4	76.2	104.6	63.5	63.5	73.2	7.9	47.8	19.1
3	267	133.4	127.0	47.8		90.7	91.4	92.2	117.3	73.2	73.2	88.9	9.7	50.8	20.6
4	311	162.1	157.2	53.8		116.1	116.8	117.6	124.0	90.4	90.4	114.3	11.2	57.2	23.9
5	375	196.9	185.7	73.2		143.8	144.5	144.5	155.4	104.6	104.6	141.2	11.2	63.5	23.9
6	394	228.6	215.9	82.6		170.7	171.5	171.5	171.5	119.1	119.1	168.4	12.7	69.9	26.9
8	483	292.1	269.7	91.9		221.5	222.3	222.3	212.9	142.7	142.7	219.2	12.7	76.2	31.8
10	584	368.3	323.9	108.0		276.4	277.4	276.4	254.0	158.8	177.8	273.1	12.7	84.1	33.3
12	673	450.9	381.0	124.0		327.1	328.2	328.7	282.4	180.8	218.9	323.9	12.7	91.9	39.6
14	749	495.3	412.8	133.4		359.2	360.2	360.4	298.5	-	241.3	355.6	12.7	-	41.4
16	826	552.5	469.9	146.1		410.5	411.2	411.2	311.2	-	260.4	406.4	12.7	-	44.5
18	914	596.9	533.4	162.1	461.8	462.3	462.0	327.2	-	276.4	457.2	12.7	-	49.3	
20	984	641.4	584.2	177.8	513.1	514.4	512.8	355.6	-	292.1	508.0	12.7	-	54.1	
24	1168	762.0	692.2	203.2	616.0	616.0	614.4	406.4	-	330.2	609.6	12.7	-	63.5	

NOTE :

1. For the 'Bore' (B1) other Standard Wall Thickness,
2. Class 1500 flanges except Lap Joint will be furnished with 0.25" (6.35mm) raised face, which is included in 'Thickness' (t) and 'Length through Hub' (T1), (T2).
3. For Slip-on, Threaded, Socket Welding and Lap Joint Flanges, the hubs can be shaped either vertical from base to top or tapered within the limits of 7 degrees.



# ANSI FLANGE

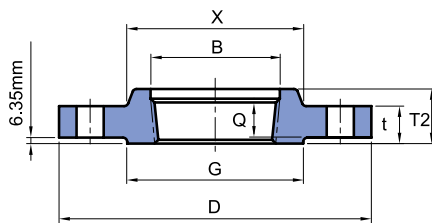

THREADED

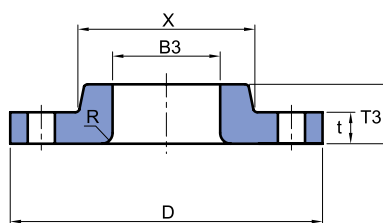

LAP JOINT

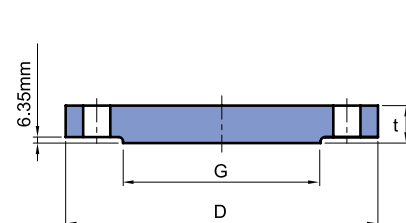

BLIND

Unit : mm

Nominal Pipe Size	DRILLING			BOLTING				APPROXIMATE WEIGHT									
	Bolt Circle Diam.	Number of Holes	Diam. of Holes	Diam. of Bolts (inch)	STUD BOLT LENGTH			Welding Neck		Slip-on and Threaded		Lap Joint		Blind		Socket Welding	
					0.25" Raised Face	Male - Female Tongue - Groove	Ring Joint	Kg	lb	Kg	lb	Kg	lb	Kg	lb	Kg	lb
1/2	82.6	4	22.4	3/4	108.0	101.6	108.0	2.10	4.60	1.80	4.00	1.80	4.00	1.90	4.00	1.81	4.00
3/4	88.9	4	22.4	3/4	114.3	108.0	114.3	2.72	6.00	2.27	5.00	2.27	5.00	2.72	6.00	2.81	6.20
1	101.6	4	25.4	7/8	127.0	120.7	127.0	3.86	8.50	3.40	7.50	3.40	7.50	4.08	9.00	3.61	8.00
1 1/4	111.3	4	25.4	7/8	127.0	120.7	127.0	4.54	10.00	4.10	9.00	4.09	10.80	4.30	9.50	4.99	11.00
1 1/2	124.0	4	28.4	1	139.7	133.4	139.7	5.90	13.00	5.45	12.00	5.40	11.90	5.90	13.00	6.76	14.90
2	165.1	8	25.4	7/8	146.1	139.7	146.1	10.89	24.00	10.50	23.00	9.53	21.00	11.30	25.00	10.89	24.00
2 1/2	190.5	8	28.4	1	158.8	152.4	158.8	16.34	36.00	15.80	34.80	13.15	29.00	16.00	35.30	16.34	36.00
3	203.2	8	31.8	1 1/8	177.8	171.5	177.8	21.79	48.00	21.77	48.00	17.24	38.00	21.79	48.00	-	-
4	241.3	8	35.1	1 1/4	196.9	190.5	196.9	31.30	69.00	31.00	68.40	29.00	63.90	33.11	73.00	-	-
5	292.1	8	41.1	1 1/2	247.7	241.3	247.7	59.02	130.00	58.80	129.60	54.00	119.00	60.00	132.30	-	-
6	317.5	12	38.1	1 3/8	260.4	254.0	266.7	74.91	165.00	74.00	163.00	62.00	136.70	75.00	165.30	-	-
8	393.7	12	44.5	1 5/8	292.1	285.8	323.9	123.83	273.00	117.73	258.00	129.73	236.00	136.98	302.00	-	-
10	482.6	12	50.8	1 7/8	336.6	330.2	342.9	205.93	454.00	197.49	435.40	220.19	485.40	229.97	507.00	-	-
12	571.5	16	53.8	2	374.7	368.3	387.4	306.00	674.60	264.00	582.00	286.02	630.60	316.00	696.70	-	-
14	635.0	16	60.5	2 1/4	406.4	400.1	425.5	416.00	917.00	-	-	404.06	890.80	421.00	928.00	-	-
16	704.9	16	66.5	2 1/2	444.5	438.2	469.9	567.50	1250.00	-	-	522.10	1151.00	559.00	1232.70	-	-
18	774.7	16	73.2	2 3/4	495.3	489.0	527.1	736.00	1622.60	-	-	669.65	1476.30	761.00	1677.70	-	-
20	831.9	16	79.2	3	539.8	533.4	565.2	929.00	2048.00	-	-	805.85	1776.60	967.00	2131.80	-	-
24	990.6	16	91.9	3 1/2	616.0	609.6	647.7	1504.00	3315.70	-	-	1285.55	2834.00	1568.00	3456.80	-	-

4. Blind Flanges may be made with the same hub as that used for Slip-on Flanges or without hub.
5. The gasket surface and backside (bearing surface for bolting) are made parallel within 1 degree. To accomplish parallelism, spot facing is carried out according to MSS SP-9, without reducing thickness (t).
- 6 Dimensions of sizes 1/2" through 2 1/2" are the same as for Class 900 Flanges.
7. Depth of Socket (Y) is covered by ANSI B 16.5 only in sizes through 2 1/2 inch, over 2 1/2 inch is at the manufacturer's option.

## CLASS 2500 FLANGES

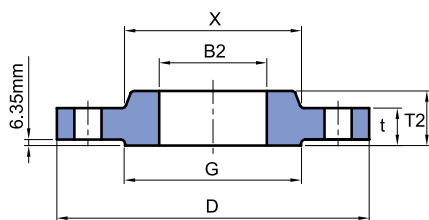

SLIP-ON

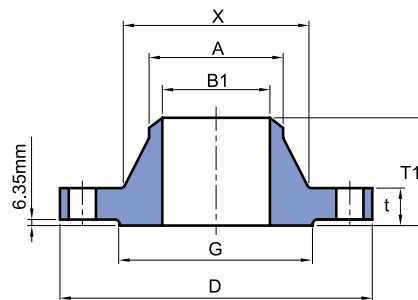

WELDING NECK

## ANSI B 16.5 Forged Flanges

Unit : mm

Nominal Pipe Size	Outside Diam.	Diam. at Base of Hub	O.D of Raised Face	Thickness	BORE				LENGTH THRU HUB			Diam. of Hub at Bevel	Radius of Fillet	Thread Length	
					Welding Neck	Slip-on	Lap Joint	Counter Bore Min.	Welding Neck	Slip-on Threaded	Lap Joint				
															B1
1/2	133	42.9	35.1	30.2	To be specified by purchaser.										
3/4	140	50.8	42.9	31.8			22.4	22.9	23.6	73.2	39.6	39.6	21.3	3.0	28.4
1	159	57.2	50.8	35.1			27.7	28.2	29.0	79.2	42.9	42.9	26.7	3.0	31.8
1 1/4	184	73.2	63.5	38.1			34.5	35.1	35.8	88.9	47.8	47.8	33.5	3.0	35.1
1 1/2	203	79.2	73.2	44.5			43.2	43.7	44.5	95.3	52.3	52.3	42.2	4.8	38.1
2	235	95.3	91.9	50.8			49.5	50.0	50.5	111.3	60.5	60.5	48.3	6.4	44.5
2 1/2	267	114.3	104.6	57.2			62.0	62.5	63.5	127.0	69.9	69.9	60.5	7.9	50.8
3	305	133.4	127.0	66.5			74.7	75.4	76.2	142.7	79.2	79.2	73.2	7.9	57.2
4	356	165.1	157.2	76.2			90.7	91.4	92.2	168.1	91.9	91.9	88.9	9.7	63.5
5	419	203.2	185.7	91.9			116.1	116.8	117.6	190.5	108.0	108.0	114.3	11.2	69.9
6	483	235.0	215.9	108.0			143.8	144.5	144.5	228.6	130.0	130.0	141.2	11.2	76.2
8	552	304.8	269.7	127.0			170.7	171.5	171.5	273.1	152.4	152.4	168.4	12.7	82.6
10	673	374.7	323.9	165.1		221.5	222.3	222.3	317.5	177.8	177.8	219.2	12.7	95.3	
12	762	441.5	381.0	184.2		276.4	277.4	276.4	419.1	228.6	228.6	273.1	12.7	108.0	
						327.2	328.2	328.7	463.6	254.0	254.0	323.9	12.7	120.7	

NOTE :

1. For the 'Bore' (B1) other Standard Wall Thickness.
2. Class 2500 flanges except Lap Joint will be furnished with 0.25" (6.35mm) raised face, which is included in 'Thickness' (t) and 'Length through Hub' (T1), (T2).
3. For Slip-on, Threaded, Socket Welding and Lap Joint Flanges, the hubs can be shaped either vertical from base to top or tapered within the limits of 7 degrees.

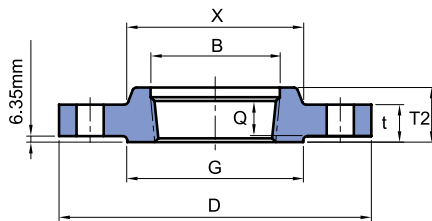

THREADED

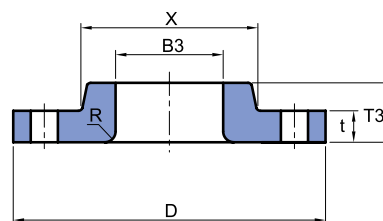

LAP JOINT

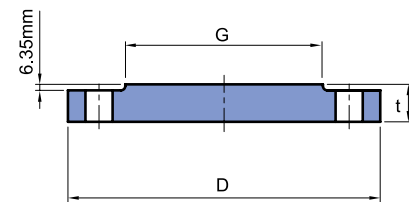

BLIND

Unit : mm

Nominal Pipe Size	DRILLING			BOLTING				APPROXIMATE WEIGHT							
	Bolt Circle Diam.	Number of Holes	Diam. of Holes	Diam. of Bolts (inch)	STUD BOLT LENGTH			Welding Neck		Slip-on and Threaded		Lap Joint		Blind	
					0.25" Raised Face	Male - Female Tongue - Groove	Ring Joint	Kg	lb	Kg	lb	Kg	lb	Kg	lb
1/2	88.9	4	22.4	3/4	120.7	114.3	120.7	3.18	7.00	3.18	7.00	3.00	6.60	3.18	7.00
3/4	95.3	4	22.4	3/4	127.0	120.7	127.0	4.08	9.00	4.08	9.00	3.63	8.00	4.54	10.00
1	108.0	4	25.4	7/8	139.7	133.4	139.7	5.45	12.00	5.44	12.00	4.99	11.00	5.44	12.00
1 1/4	130.0	4	28.4	1	152.4	146.1	152.4	9.07	20.00	8.16	18.00	7.26	16.00	8.16	18.00
1 1/2	146.1	4	31.8	1 1/8	171.5	165.1	171.5	11.35	25.00	11.00	24.30	9.99	22.00	10.44	23.00
2	171.5	8	28.4	1	177.8	171.5	177.8	19.07	42.00	17.25	38.00	16.80	37.00	17.71	39.00
2 1/2	196.9	8	31.8	1 1/8	196.9	190.5	203.2	23.61	52.00	24.97	55.00	24.06	53.00	25.42	56.00
3	228.6	8	35.1	1 1/4	222.3	215.9	228.6	42.68	94.00	37.68	83.00	36.32	80.00	39.04	86.00
4	273.1	8	41.1	1 1/2	254.0	247.7	260.4	64.00	141.00	58.00	127.90	54.48	120.00	60.38	133.00
5	323.9	8	47.8	1 3/4	298.5	292.1	311.2	110.68	244.00	95.25	210.00	92.53	204.00	101.15	223.00
6	368.3	8	53.8	2	342.9	336.6	355.6	176.46	378.00	146.51	323.00	143.01	315.30	156.63	345.30
8	438.2	12	53.8	2	381.0	374.7	393.7	261.27	576.00	219.99	485.00	213.38	470.40	240.62	530.50
10	539.8	12	66.5	2 1/2	489.0	482.6	508.0	484.43	1068.00	419.57	925.00	408.60	900.80	465.36	1026.00
12	619.3	12	73.2	2 3/4	539.8	533.4	558.8	692.35	1526.30	590.20	1301.00	572.95	1263.00	664.06	1464.00

- 4. Blind Flanges may be made with the same hub as that used for Slip-on Flanges or without hub.
- 5. The gasket surface and backside (bearing surface for bolting) are made parallel within 1 degree. To accomplish parallelism, spot facing is carried out according to MSS SP-9, without reducing thickness (t).
- 7. Class 2500 Slip-on Flanges are not covered by ANSI B16.5, slip-on flanges are at the manufacture's option.

## REDUCING FLANGES

### Threaded and Slip-on Types

#### ■ HUB

For hub diameter (X) and height of hub above the back of the flange (N) refer to the list of standard flange specification of the same type and pressure and use the dimensions of a flange one nominal pipe size smaller than the nominal pipe size from which the reduction is being made.

#### ■ FLANGE O.D., DRILLING TEMPLATE AND THICKNESS

Outside diameter, drilling template and flange thickness Q (See note on FACINGS) agree with the dimensions of a standard flange of the nominal pipe size from which the reduction is being made.

#### ■ FACING

Facing dimensions also agree with the dimensions of a standard flange of the nominal pipe size from which the reduction is being made.

150 lb. and 300 lb. forged steel Threaded, Slip-On, Welding Neck and Blind flanges are furnished with American Standard 1/16" raised face which is included in flange thickness. Q. 400 lb., 600 lb., 900 lb., 1500 lb., 1500 lb. and 2500 lb. flange are supplied with American Standard 1/4" raised face which is not included in flange thickness (Q)

#### ■ BORE OR TAPPING

The bore or tapping is machined to accept a pipe of the nominal pipe size to which the reduction is being made. For reduction to size smaller than shown, BLIND FLANGE are tapped or bored to specified nominal pipe size.

#### EXAMPLE :

A 300 lb. threaded flange used in reducing from a 6" (152.4mm) to 3" (76.2mm) nominal pipe size should be specified as a 3" (76.2mm) x 12 1/2" - 300 lb. Threaded Reducing Flange. It would have the following dimensional characteristics :

Diameter of Hub (X) - 7" (177.8mm).

Height of Hub (N) - 5/8".

Hub dimensions are those of a 5" (127.0mm), 300lb, Standard flange.

Outside Diameter - 12 1/2"

Thickness (Q) - 1 7/16"

Raised face - 1/16".

O.D., Flange Thickness Q, Raised Face and Drilling Template are those of a 6" (152.4mm), 300lb. Standard Flange.

Tapping - 3" (76.2mm) I.P.S.

Flange is tapped to the nominal pipe size to which reduction is being made.

#### WELDING NECK TYPES

On Reducing Welding Neck Flanges, which are made only on special order, the hub dimensions agree with the hub dimensions of standard flanges of the size to which reduction is being made. Other flange dimensions, including the drilling template, agree with the standard dimensions of the size from which the reduction is being made.

# REDUCING FLANGES

Threaded-Slip-on-Welding neck

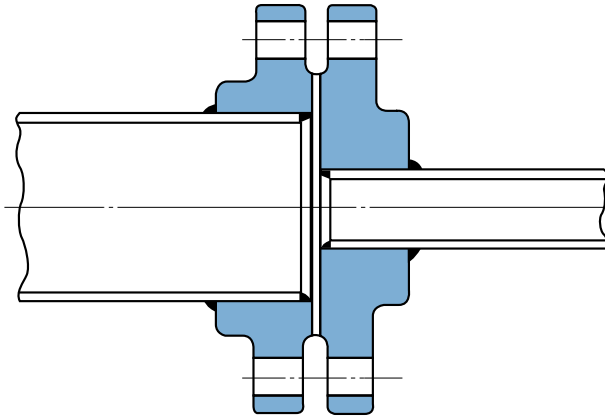

In ordering Reducing Flanges : specify (1) nominal pipe size of the tapping or bore to which the reduction is being made. (2) the outside diameter of the flange from which the reduction is being made and (3) pressure rating.

**EXAMPLE :**

A 300 lb. Reducing flange for reducing from a 6" (152.4mm) to a 3" (76.2mm) nominal pipe size should be designated as a 3" (76.2mm) x 12 1/2" - 300 lb. Reducing Flange. Whether Threaded, Slip-On, or Welding Neck type is desired must also be specified.

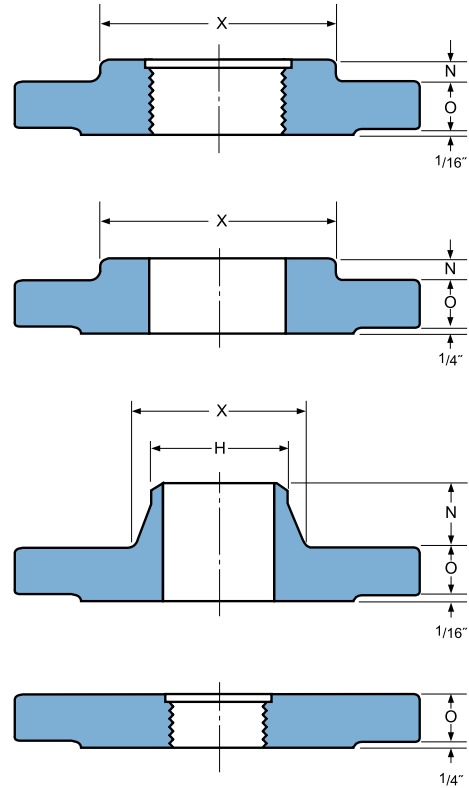

## ANSI B 16.5 Forged Flanges

Dimensions inches.

Nominal Flange	OUTSIDE DIAMETER OF FLANGE FROM WHICH REDUCTION IS BEING MADE							Smallest Size Bore or Tapping Requiring Hub Flange
	150 lb. Standard	300 lb. Standard	400 lb. Standard	600 lb. Standard	900 lb. Standard	1500 lb. Standard	2500 lb. Standard	
3/4	3 7/8	4 5/8	4 5/8	4 5/8	5 1/8	5 1/8	5 1/2	1/2
1	4 1/4	4 7/8	4 7/8	4 7/8	5 7/8	5 7/8	6 1/4	1/2
1 1/4	4 5/8	5 1/4	5 1/4	5 1/4	6 1/4	6 1/4	7 1/4	1/2
1 1/2	5	6 1/8	6 1/8	6 1/8	7	7	8	1/2
2	6	6 1/2	6 1/2	6 1/2	8 1/2	8 1/2	9 1/4	1
2 1/2	7	7 1/2	7 1/2	7 1/2	9 5/8	9 5/8	10 1/2	1 1/4
3	7 1/2	8 1/4	8 1/4	8 1/4	9 1/2	10 1/2	12	1 1/4
3 1/2	8 1/2	9	9	9	-	-	-	1 1/2
4	9	10	10	10 3/4	11 1/2	12 1/4	14	1 1/2
5	10	11	11	13	13 3/4	14 3/4	16 1/2	1 1/2
6	11	12 1/2	12 1/2	14	15	15 1/2	19	2 1/2
8	13 1/2	15	15	16 1/2	18 1/2	19	21 3/4	3
10	16	17 1/2	17 1/2	20	21 1/2	23	26 1/2	3 1/2
12	19	20 1/2	20 1/2	22	24	26 1/2	30	3 1/2
14	21	23	23	23 3/4	25 1/4	-	-	3 1/2
16	23 1/2	25 1/2	25 1/2	27	27 3/4	-	-	4
18	25	28	28	29 1/4	31	-	-	4
20	27 1/2	30 1/2	30 1/2	32	33 3/4	-	-	4
24	32	36	36	37	41	-	-	4

NOTE : For reductions to size smaller than shown, blind flange are tapped or bored for specified nominal pipe size.



# CLASSES AVAILABLE

## ASME B16.5

- ◆ 150#, 300#, 400#, 600#, 900#, 1500#, 2500#

## ASME B16.47 Ser. A & Ser. B, Industry Standard and A.W.W.A. Flanges:

- ◆ Series A MSS SP44
- ◆ Series B API 605
- ◆ Class 75 per ASME 16.47 Ser. B
- ◆ Class 75 per Industry Standard
- ◆ Class 75 per Industry Standard
- ◆ Class 125 LW, A.W.W.A C207 Class B & D
- ◆ Class 125, A.W.W.A C207 Class E
- ◆ Class 150 Welding Neck per ASME 16.47 Ser. A
- ◆ Class 150 Welding Neck per ASME 16.47 Ser. B
- ◆ Class 175 Industry Standard
- ◆ Class 300 Welding Neck & Blind per ASME B16.47 Ser. A
- ◆ Class 300 Welding Neck & Blind per ASME B16.47 Ser. B
- ◆ Class 300 Welding Neck Industry Standard
- ◆ Class 350 Slip-On Industry Standard
- ◆ Class 400 ASME B16.47 Ser. A & B
- ◆ Class 600 ASME B16.47 Ser. A & B

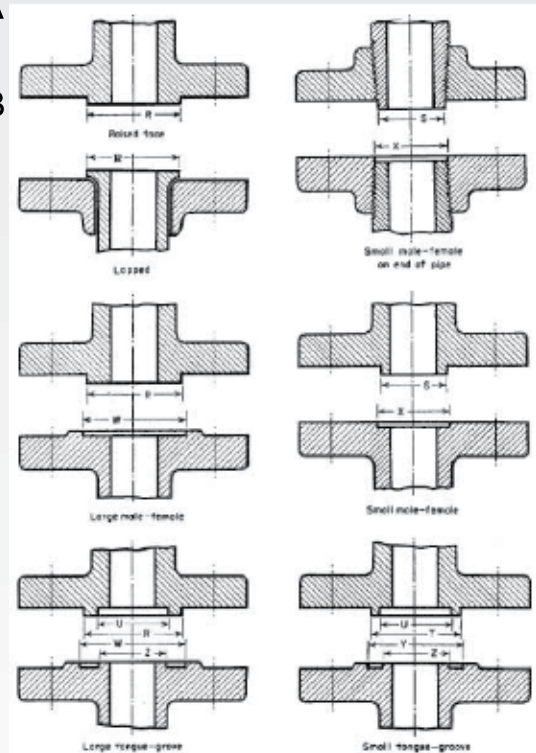

# FLANGE FACING AND FINISHING



When ordered, these flange types can be furnished with a variety of other facings, such as male and female, ring joint, tongue and groove, etc. Lap Joint flanges are machined with a flat face and a fillet radius to accommodate the stub end or pipe lap.

## Flange Face Surface Finish

The ASME B16.5 code requires that the flange face (raised face and flat face) has a specific roughness to ensure that this surface be compatible with the gasket and provide a high quality seal.

A serrated finish, either concentric or spiral, is required with 30 to 55 grooves per inch and a resultant roughness between 125 and 500 micro inches. This allows for various grades of surface finish to be made available by flange manufactures for the gasket contact surface of metal flanges.

### Stock Finish

The most widely used of any flange surface finish, because practically, is suitable for all ordinary service conditions. Under compression, the soft face from a gasket will embed into this finish, which helps create a seal, and a high level of friction is generated between the mating surfaces.

### Spiral Serrated

This is also a continuous or pornographic spiral groove, but it differs from the stock finish in that the groove typically is generated using a 90-deg tool which creates a "V" geometry with 45° angled serration.

### Concentric Serrated

As the name suggests, this finish is comprised of concentric grooves. A 90° tool is used and the serrations are spaced evenly across the face.

### Smooth Finish

This finish shows no visually apparent tool markings. These finishes are typically utilized for gaskets with metal facings such as double jacketed, flat steel and corrugated metal. The smooth surfaces mate to create a seal and depend on the flatness of the opposing faces to effect a seal.

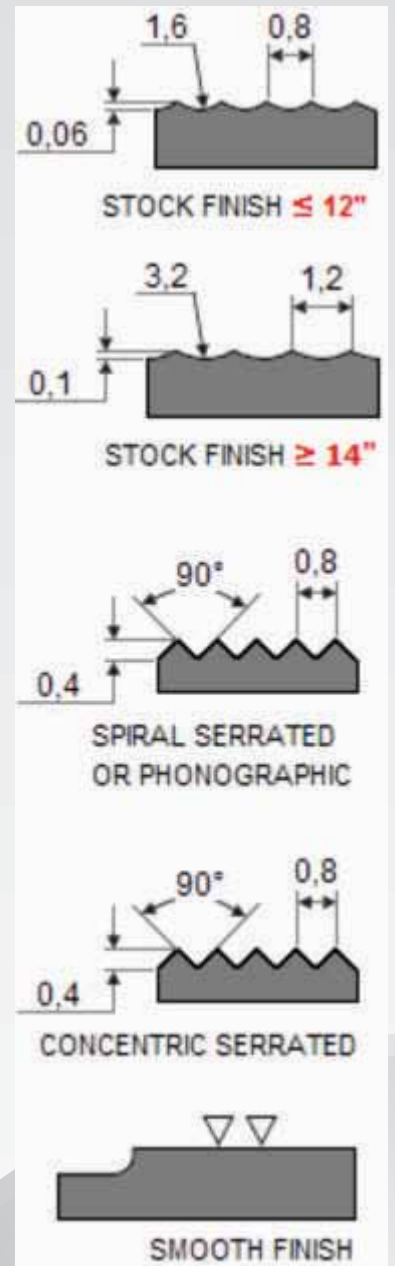

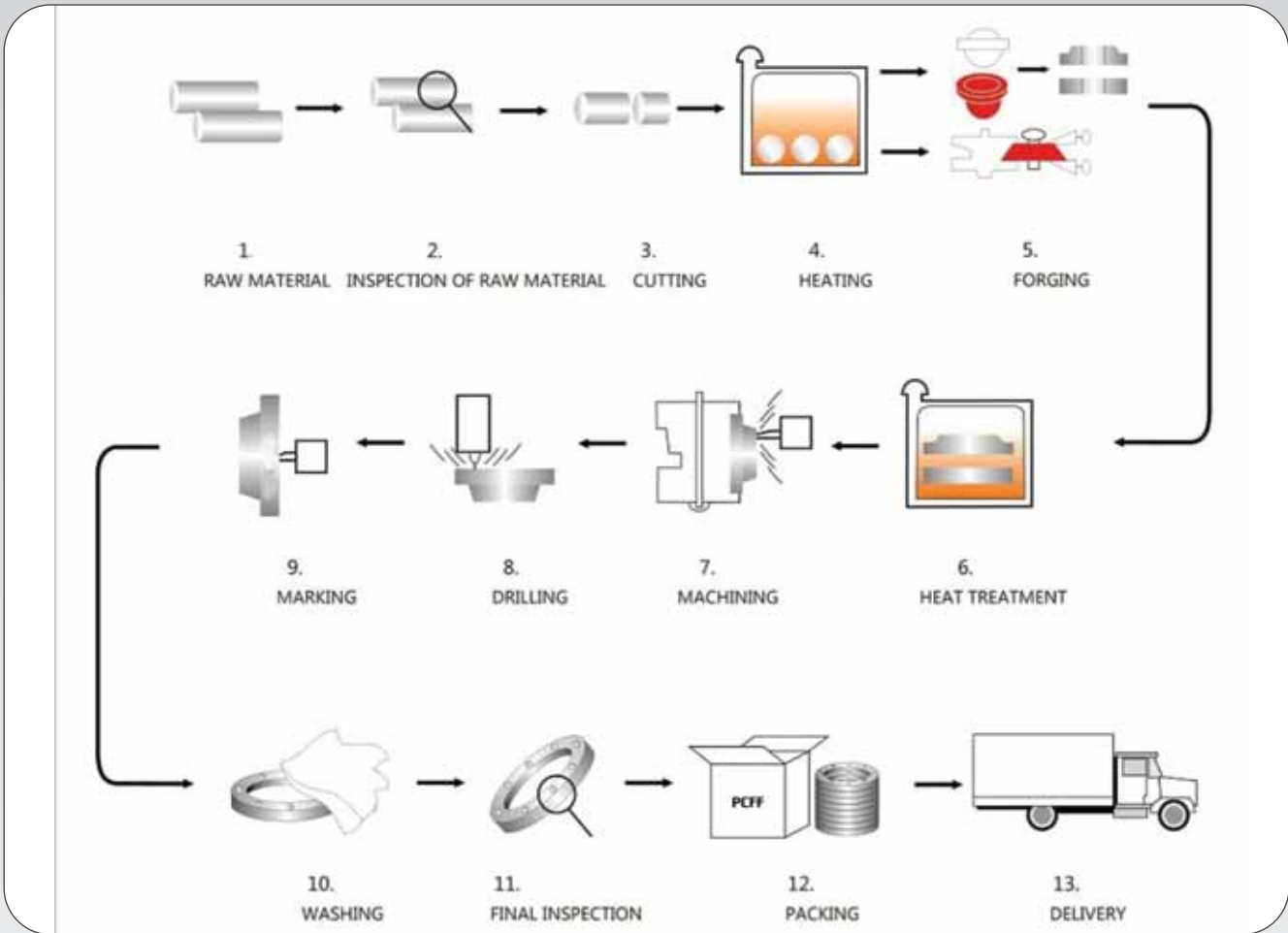

Flange Production Process

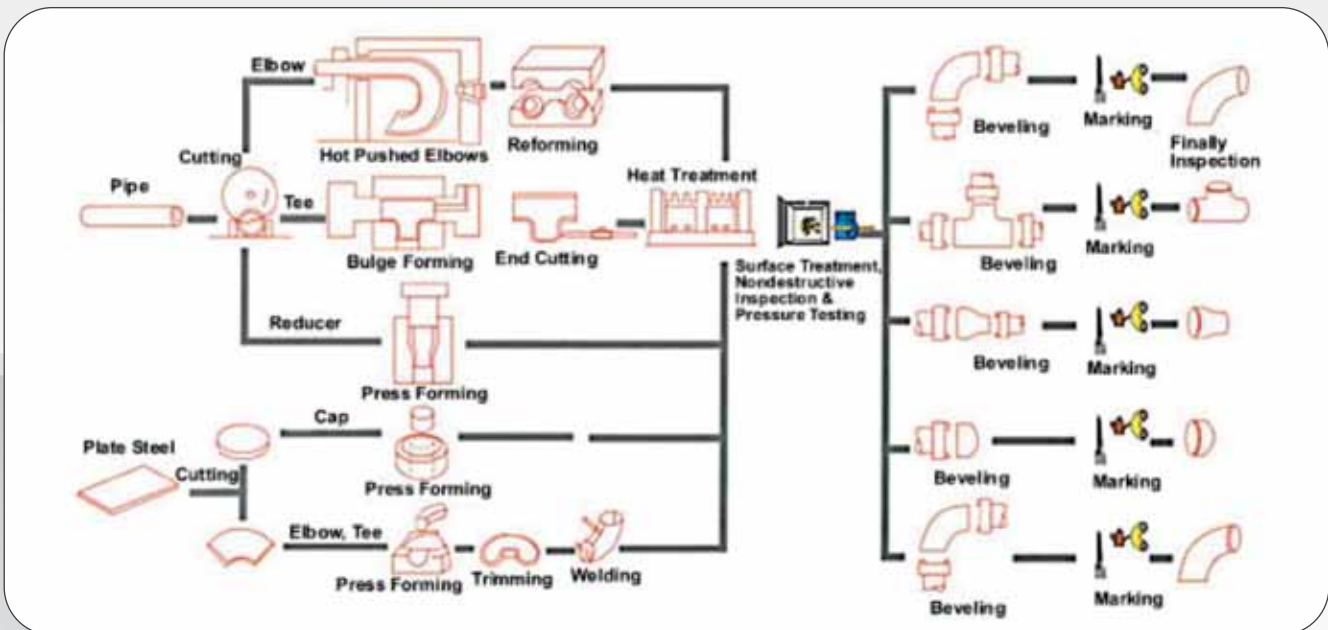

Fittings Production Process



# RING JOINT FLANGES

- Class 150 Flanges
- Class 300 / 400 / 600 Flanges
- Class 900 Flanges
- Class 1500 Flanges
- Class 2500 Flanges

## CLASS 150 FLANGES

### Ring Joint Flanges Facing Dimensions

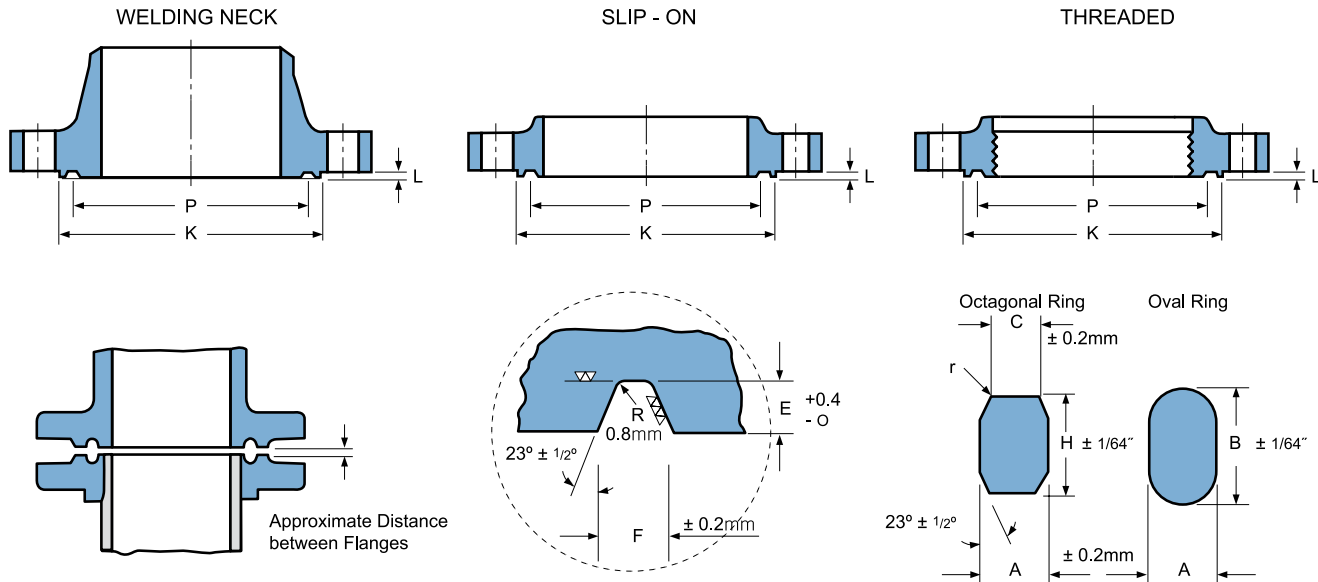

## ANSI B 16.5 Forged Flanges

Unit : mm

Nominal Pipe Size	Pitch Diam. of Ring and Groove	Width of Ring	HEIGHT OF RING		Width of Flat on Octagonal Rings	Width of Groove	Depth of Groove	Diameter of Raised Face for Ring Joint or Lapped	Ring Number	Approximate Distance Between Flange of Ring Joints When Ring is Compressed
			OVal	Octagonal						
	P	A	B	H	C	F	E(L*)	K(Min)		
1	47.6	8.0	14.3	12.7	5.2	8.7	6.4	63.5	R15	4.1
1 1/4	57.2	8.0	14.3	12.7	5.2	8.7	6.4	73.2	R17	4.1
1 1/2	65.1	8.0	14.3	12.7	5.2	8.7	6.4	82.6	R19	4.1
2	82.6	8.0	14.3	12.7	5.2	8.7	6.4	101.6	R22	4.1
2 1/2	101.6	8.0	14.3	12.7	5.2	8.7	6.4	120.7	R25	4.1
3	114.3	8.0	14.3	12.7	5.2	8.7	6.4	133.4	R29	4.1
3 1/2	131.8	8.0	14.3	12.7	5.2	8.7	6.4	153.9	R33	4.1
4	149.2	8.0	14.3	12.7	5.2	8.7	6.4	171.5	R36	4.1
5	171.5	8.0	14.3	12.7	5.2	8.7	6.4	193.5	R40	4.1
6	193.7	8.0	14.3	12.7	5.2	8.7	6.4	218.9	R43	4.1
8	247.7	8.0	14.3	12.7	5.2	8.7	6.4	273.1	R48	4.1
10	304.8	8.0	14.3	12.7	5.2	8.7	6.4	330.2	R52	4.1
12	381.0	8.0	14.3	12.7	5.2	8.7	6.4	406.4	R56	4.1
14	396.9	8.0	14.3	12.7	5.2	8.7	6.4	425.5	R59	3.0
16	454.0	8.0	14.3	12.7	5.2	8.7	6.4	482.6	R64	3.0
18	517.5	8.0	14.3	12.7	5.2	8.7	6.4	546.1	R68	3.0
20	558.8	8.0	14.3	12.7	5.2	8.7	6.4	596.9	R72	3.0
24	673.1	8.0	14.3	12.7	5.2	8.7	6.4	711.2	R76	3.0

**NOTE :**

1. Unless other wise specified by the customer, Ring Type Joint Flanges will be furnished in accordance with these details.
2. The depth of groove is added to the minimum flange thickness.

\* Raised face " L " is equal to groove dimension " E " but is not subject to tolerances for " E "

\* A plus tolerance of 3/64 in, for heights B and H is permitted providing the variation in the height of any given ring does not exceed 1/64 in, throughout its entire circumference.



## CLASS 300 / 400 / 600 FLANGES

### Ring Joint Flanges Facing Dimensions

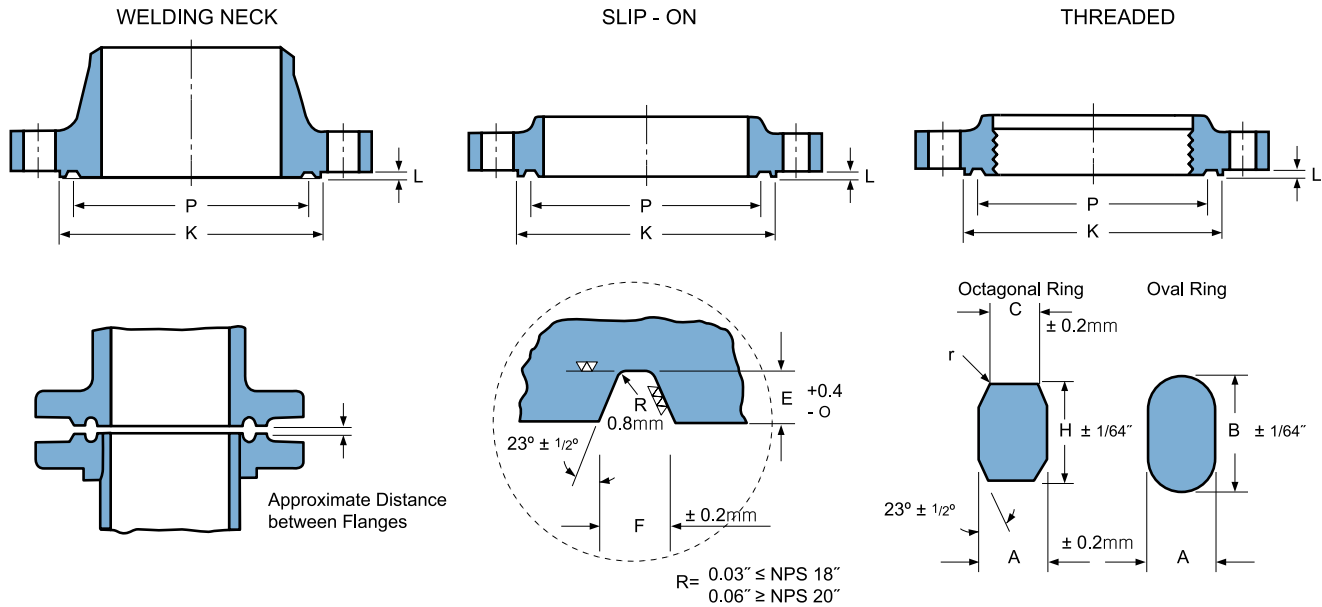

## ANSI B 16.5 Forged Flanges

Unit : mm

Nominal Pipe Size	Pitch Diam. of Ring and Groove	Width of Ring	HEIGHT OF RING		Width of Flat on Octagonal Rings	Width of Groove	Depth of Groove	Diameter of Raised Face for Ring Joint or Lapped	Ring Number	Approximate Distance Between Flange of Ring Joints When Ring is Compressed		
			Oval	Octagonal						Class 300	Class 400	Class 600
			B	H								
P	A	B	H	C	F	E(L*)	K(Min)					
1/2	34.1	6.4	11.1	9.5	4.3	7.1	5.6	50.8	R11	3.0	-	3.0
3/4	42.9	8.0	14.3	12.7	5.2	8.7	6.4	63.5	R13	4.1	-	4.1
1	50.8	8.0	14.3	12.7	5.2	8.7	6.4	69.9	R16	4.1	-	4.1
1 1/4	60.3	8.0	14.3	12.7	5.2	8.7	6.4	79.5	R18	4.1	-	4.1
1 1/2	68.3	8.0	14.3	12.7	5.2	8.7	6.4	90.4	R20	4.1	-	4.1
2	82.6	11.1	17.5	15.9	7.7	11.9	7.9	108.0	R23	5.6	-	4.8
2 1/2	101.6	11.1	17.5	15.9	7.7	11.9	7.9	127.0	R26	5.6	-	4.8
3	123.8	11.1	17.5	15.9	7.7	11.9	7.9	146.1	R31	5.6	-	4.8
3 1/2	131.8	11.1	17.5	15.9	7.7	11.9	7.9	158.8	R34	5.6	-	4.8
4	149.2	11.1	17.5	15.9	7.7	11.9	7.9	174.8	R37	5.6	5.6	4.8
5	181.0	11.1	17.5	15.9	7.7	11.9	7.9	209.6	R41	5.6	5.6	4.8
6	211.2	11.1	17.5	15.9	7.7	11.9	7.9	241.3	R45	5.6	5.6	4.8
8	269.9	11.1	17.5	15.9	7.7	11.9	7.9	301.8	R49	5.6	5.6	4.8
10	323.9	11.1	17.5	15.9	7.7	11.9	7.9	355.6	R53	5.6	5.6	4.8
12	381.0	11.1	17.5	15.9	7.7	11.9	7.9	412.8	R57	5.6	5.6	4.8
14	419.1	11.1	17.5	15.9	7.7	11.9	7.9	457.2	R61	5.6	5.6	4.8
16	469.9	11.1	17.5	15.9	7.7	11.9	7.9	508.0	R65	5.6	5.6	4.8
18	533.4	11.1	17.5	15.9	7.7	11.9	7.9	574.8	R69	5.6	5.6	4.8
20	584.2	12.7	19.1	17.5	8.7	13.5	9.5	635.0	R73	5.6	5.6	4.8
24	692.2	15.9	22.2	20.7	10.5	16.7	11.1	749.3	R77	6.4	6.4	5.6

NOTE :

- Unless other wise specified by the customer, Ring Type Joint Flanges will be furnished in accordance with these details.
- The depth of groove is added to the minimum flange thickness.
  - \* Raised face "L" is equal to groove dimension "E" but is not subject to tolerances for "E"
  - \* A plus tolerance of 3/64 in, for heights B and H is permitted providing the variation in the height of any given ring does not exceed 1/64 in, throughout its entire circumference.
- Dimension "R" is max.
- Radius "r" is 1/16" for ring widths 7/8" and less and 3/32" for ring widths 1"(25.4mm) and over.

## CLASS 900 FLANGES

### Ring Joint Flanges Facing Dimensions

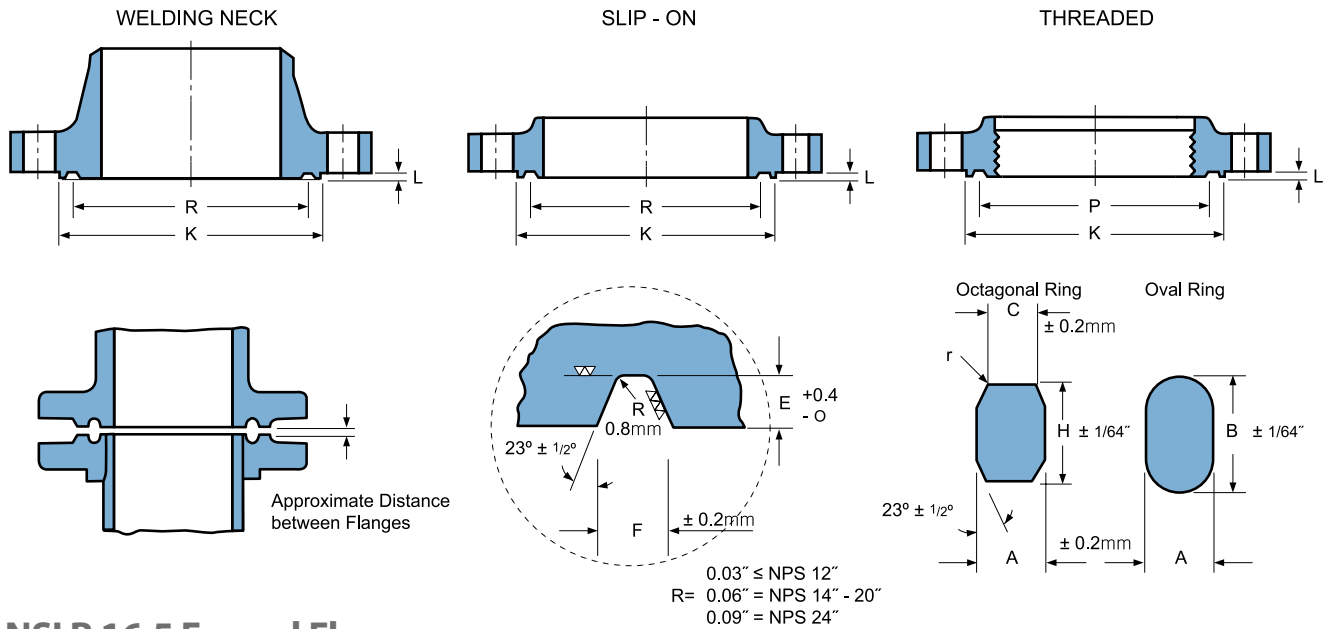

## ANSI B 16.5 Forged Flanges

Unit : mm

Nominal Pipe Size	Pitch Diam. of Ring and Groove	Width of Ring	HEIGHT OF RING		Width of Flat on Octagonal Rings	Width of Groove	Depth of Groove	Diameter of Raised Face for Ring Joint or Lapped	Ring Number	Approximate Distance Between Flange of Ring Joints When Ring is Compressed
			Oval	Octagonal						
	P	A	B	H	C	F	E(L*)	K(Min)		

For size 2 1/2 and smaller, use Class 1500 Ring Joint Flanges

3	123.8	11.1	17.5	15.9	7.7	11.9	7.9	155.4	R31	4.1
4	149.2	11.1	17.5	15.9	7.7	11.9	7.9	180.8	R37	4.1
5	181.0	11.1	17.5	15.9	7.7	11.9	7.9	215.9	R41	4.1
6	211.2	11.1	17.5	15.9	7.7	11.9	7.9	241.3	R45	4.1
8	269.9	11.1	17.5	15.9	7.7	11.9	7.9	307.8	R49	4.1
10	323.9	11.1	17.5	15.9	7.7	11.9	7.9	362.0	R53	4.1
12	381.0	11.1	17.5	15.9	7.7	11.9	7.9	419.1	R57	4.1
14	419.1	15.9	22.2	20.7	10.5	16.7	11.1	466.9	R62	4.1
16	469.9	15.9	22.2	20.7	10.5	16.7	11.1	523.7	R66	4.1
18	533.4	19.1	25.4	23.8	11.1	19.8	12.7	593.9	R70	4.8
20	584.2	19.1	25.4	23.8	12.3	19.8	12.7	647.7	R74	4.8
24	692.2	25.4	33.4	31.8	17.3	27.0	15.9	771.7	R78	5.6

**NOTE :**

- Unless other wise specified by the customer, Ring Type Joint Flanges will be furnished in accordance with these details.
- The depth of groove is added to the minimum flange thickness.
  - \* Raised face " L " is equal to groove dimension " E " but is not subject to tolerances for " E "
  - \* A plus tolerance of 3/64 in, for heights B and H is permitted providing the variation in the height of any given ring does not exceed 1/64 in, throughout its entire circumference.
- Dimension " R " is max.
- Radius " r " is 1/16" for ring widths 7/8" and less and 3/32" for ring widths 1"(25.4mm) and over.

## CLASS 1500 FLANGES

### Ring Joint Flanges Facing Dimensions

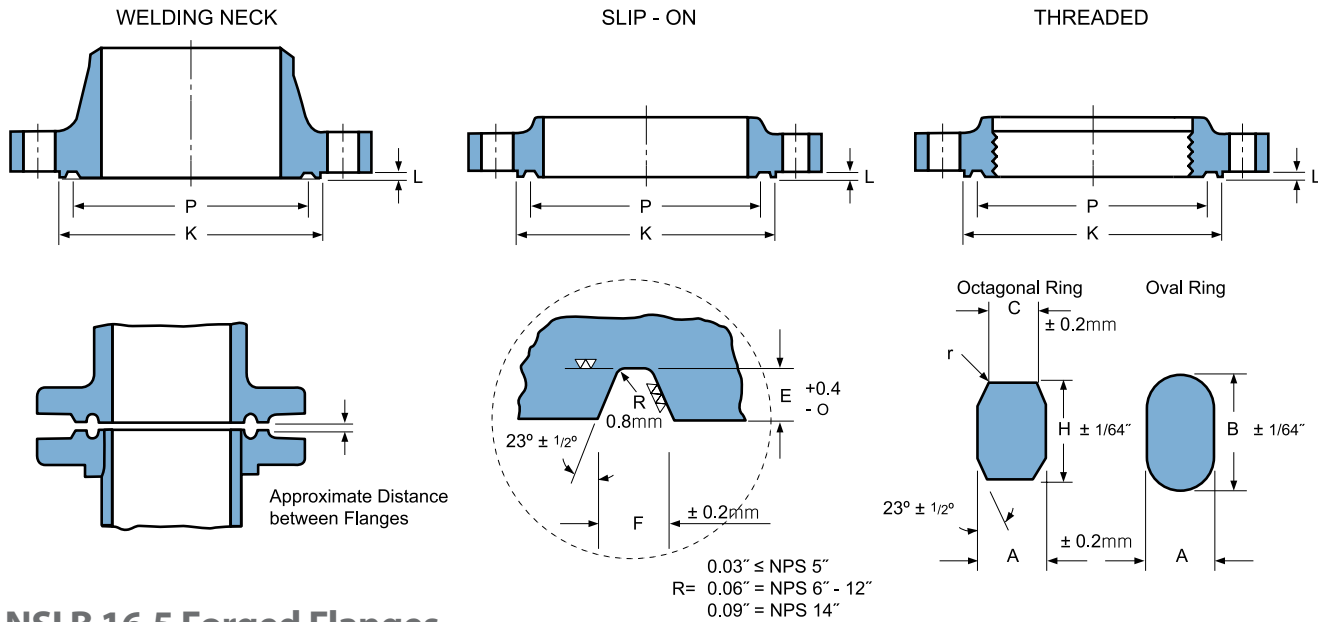

## ANSI B 16.5 Forged Flanges

Unit : mm

Nominal Pipe Size	Pitch Diam. of Ring and Groove	Width of Ring	HEIGHT OF RING		Width of Flat on Octagonal Rings	Width of Groove	Depth of Groove	Diameter of Raised Face for Ring Joint or Lapped	Ring Number	Approximate Distance Between Flange of Ring Joints When Ring is Compressed
			Oval	Octagonal						
			P	A						
1/2	39.7	8.0	14.3	12.7	5.2	8.7	6.4	60.5	R12	4.1
3/4	44.5	8.0	14.3	12.7	5.2	8.7	6.4	66.8	R14	4.1
1	50.8	8.0	14.3	12.7	5.2	8.7	6.4	71.4	R16	4.1
1 1/4	60.3	8.0	14.3	12.7	5.2	8.7	6.4	81.0	R18	4.1
1 1/2	68.3	8.0	14.3	12.7	5.2	8.7	6.4	92.2	R20	4.1
2	95.3	11.1	17.5	15.9	7.7	11.9	7.9	124.0	R24	3.0
2 1/2	108.0	11.1	17.5	15.9	7.7	11.9	7.9	136.7	R27	3.0
3	136.5	11.1	17.5	15.9	7.7	11.9	7.9	168.4	R35	3.0
4	161.9	11.1	17.5	15.9	7.7	11.9	7.9	193.8	R39	3.0
5	193.7	11.1	17.5	15.9	7.7	11.9	7.9	228.6	R44	3.0
6	211.2	12.7	19.1	17.5	8.7	13.5	9.5	247.7	R46	3.0
8	269.9	15.9	22.2	20.7	10.5	16.7	11.1	317.5	R50	4.1
10	323.9	15.9	22.2	20.7	10.5	16.7	11.1	371.6	R54	4.1
12	381.0	22.2	28.6	27.0	14.8	23.0	14.3	438.2	R58	4.8
14	419.1	25.4	33.4	31.8	17.3	27.0	15.9	489.0	R64	5.6
16	469.9	28.6	36.5	34.9	19.8	30.2	17.5	546.1	R67	7.9
18	533.4	28.6	36.5	34.9	19.8	30.2	17.5	612.9	R71	7.9
20	584.2	31.8	39.7	38.1	22.3	33.4	17.5	673.1	R75	9.7
24	692.2	34.9	44.5	41.3	24.8	36.5	20.6	793.8	R79	11.2

**NOTE :**

1. Unless other wise specified by the customer, Ring Type Joint Flanges will be furnished in accordance with these details.
2. The depth of groove is added to the minimum flange thickness.  
 \* Raised face " L " is equal to groove dimension " E " but is not subject to tolerances for " E "  
 \* A plus tolerance of 3/64 in, for heights B and H is permitted providing the variation in the height of any given ring does not exceed 1/64 in, throughout its entire circumference.
3. Dimension " R " is max.
4. Radius " r " is 1/16" for ring widths 7/8" and less and 3/32" for ring widths 1"(25.4mm) and over.

## CLASS 2500 FLANGES

### Ring Joint Flanges Facing Dimensions

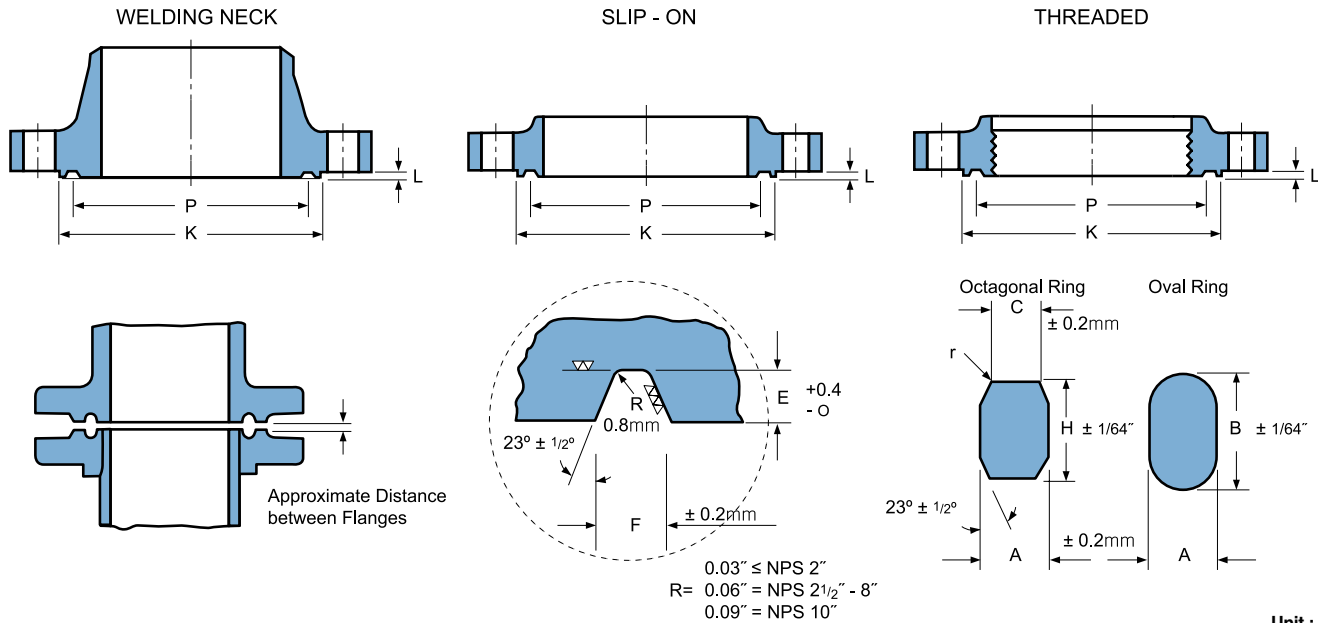

Unit : mm

Nominal Pipe Size	Pitch Diam. of Ring and Groove	Width of Ring	HEIGHT OF RING		Width of Flat on Octagonal Rings	Width of Groove	Depth of Groove	Diameter of Raised Face for Ring Joint or Lapped	Ring Number	Approximate Distance Between Flange of Ring Joints When Ring is Compressed
			OVal	Octagonal						
			P	A						
1/2	42.9	8.0	14.3	12.7	5.2	8.7	6.4	65.0	R13	4.1
3/4	50.8	8.0	14.3	12.7	5.2	8.7	6.4	73.2	R16	4.1
1	60.3	8.0	14.3	12.7	5.2	8.7	6.4	82.6	R18	4.1
1 1/4	72.2	11.1	17.5	15.9	7.7	11.9	7.9	101.6	R21	3.0
1 1/2	82.6	11.1	17.5	15.9	7.7	11.9	7.9	114.3	R23	3.0
2	101.6	11.1	17.5	15.9	7.7	11.9	7.9	133.4	R26	3.0
2 1/2	111.1	12.7	19.1	17.5	8.7	13.5	9.5	149.4	R28	3.0
3	127.0	12.7	19.1	17.5	8.7	13.5	9.5	168.4	R32	3.0
4	157.2	15.9	22.2	20.7	10.5	16.7	11.1	203.2	R38	4.1
5	190.5	19.1	25.4	23.8	12.3	19.8	12.7	241.3	R42	4.1
6	228.6	19.1	25.4	23.8	12.3	19.8	12.7	279.4	R47	4.1
8	279.4	22.2	28.6	27.0	14.8	23.0	14.3	339.9	R51	4.8
10	342.9	28.6	36.5	34.9	19.8	30.2	17.5	425.5	R55	6.4
12	406.4	31.8	39.7	38.1	22.3	33.4	17.5	495.3	R60	7.9

**NOTE :**

- Unless other wise specified by the customer, Ring Type Joint Flanges will be furnished in accordance with these details.
- The depth of groove is added to the minimum flange thickness.
  - \* Raised face " L " is equal to groove dimension " E " but is not subject to tolerances for " E "
  - \* A plus tolerance of 3/64 in, for heights B and H is permitted providing the variation in the height of any given ring does not exceed 1/64 in, throughout its entire circumference.
- Dimension " R " is max.
- Radius " r " is 1/16" for ring widths 7/8" and less and 3/32" for ring widths 1"(25.4mm) and over.

## OUR SERVICES

Top workmanship



Best in class Workmanship is our top priority to produce top Quality

Quality Assurance



Strict quality assurance resulted trust of our Customers

Delivery



On time delivery, committed to understand customer's urgency

Precision

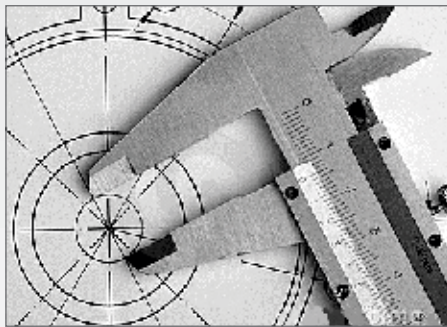

Precise in production according to customer's required size

Custom Solutions



Capacity to produce Custom Flange on customer's request on short notice



**Services:**

Manufacturer of top quality Flange and Fittings for Oil and Chemical Industry.  
We also make Custom Flange and Fittings according to customer's requirement on quick turnaround.

**Vision:**

To become the benchmark manufacturing company for the PetroChemical industry providing world-class products to satisfied customers through continuous improvement driven by the integrity, teamwork and creativity of our people.

**Mission:**

Our Company is committed to provide the highest quality product possible through our highly skilled and dedicated employee with the highest level of technical knowledge in the industry. We will achieve excellence through identifying, communicating and promoting: Quality, Knowledge and Precision.

**Values:**

The following are our core values against which we measure ourselves in the way in which we do business on a day-to-day basis:

**Integrity**– We will conduct our business in a way that makes us proud, doing what we promise to do and doing it in the right way.

**Teamwork**– Partnerships are our greatest strength both internally and externally. We will come together and strive for continuous improvement in all we do and encourage every individual to realize our full potential.

**Respect**– Everyone is important to us and we will respect our customers, partners, and suppliers and the trust they place in doing business with us. We will strive to serve to the greatest of our abilities through understanding and exceeding expectations.

**Innovation**– We will support and encourage the sharing of ideas, insights and experiences to continually improve our products, processes and capabilities for the benefit of our customers.

**Performance**– Underpins our success in all we do. Through continuously challenging and measuring ourselves we will achieve our vision of becoming the benchmark against which all other manufacturing companies are measured.



# INDUSTRIES WE SERVE



**Petroleum**



**Offshore Platforms**



**Chemical Industry**



**Shipyards Industry**



**Pharmaceutical Industry**



**Water Treatment**



**Food & Beverage Industry**



**Chemical Industry**



# JIS / KS FLANGES

- Class 5K Flanges
- Class 10K Flanges
- Class 16K Flanges
- Class 20K Flanges
- Class 30K Flanges
- Class 40K Flanges
- Class 210Kgf/cm<sup>2</sup> Flanges for Oil Pressure
- Class 280Kgf/cm<sup>2</sup> Flanges for Oil Pressure
- Class 350Kgf/cm<sup>2</sup> Flanges for Oil Pressure
- Tolerance for pipe Flanges

## 5K KS B1503 / JIS B2220

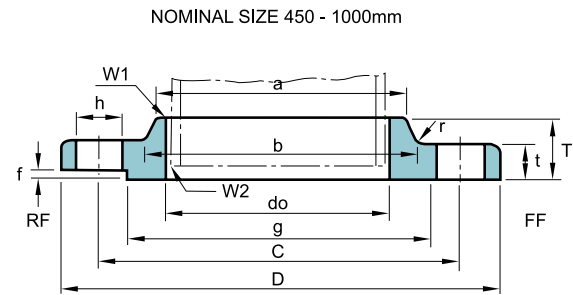
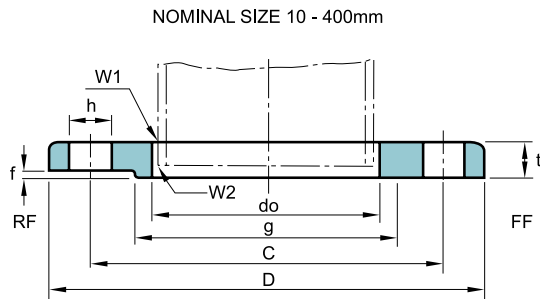

Unit : mm

Nominal Bore of Flange	Outside Dia. of Appli- cable pipe	Inside Dia. of Flange	Outside Dia. of Flange	SECTIONAL DIMENSIONS OF FLANGE									DIA. OF BOLT			Welding		Weight (kg)
				t	T	Dia. of Hub		Radius	Raised Face	Dia. of Raised Face	Dia. of Bolt Circle	Number of Bolt Holes	Hole Dia.	Nominal Bolt Size	W1	W2		
						a	b										r	
(10)	17.3	17.8	75	9	-	-	-	-	1	39	55	4	12	M10	5.0	2.5	0.27	
15	21.7	22.2	80	9	-	-	-	-	1	44	60	4	12	M10	5.0	3.0	0.30	
(20)	27.2	27.7	85	10	-	-	-	-	1	49	65	4	12	M10	5.0	3.0	0.37	
25	34.0	34.5	95	10	-	-	-	-	1	59	75	4	12	M10	5.0	3.0	0.45	
(32)	42.7	43.2	115	12	-	-	-	-	2	70	90	4	15	M12	6.0	3.0	0.78	
40	48.6	49.1	120	12	-	-	-	-	2	75	95	4	15	M12	6.0	3.0	0.83	
50	60.5	61.1	130	14	-	-	-	-	2	85	105	4	15	M12	6.0	3.0	1.07	
65	76.3	77.1	155	14	-	-	-	-	2	110	130	4	15	M12	6.0	4.0	1.49	
80	89.1	90.0	180	14	-	-	-	-	2	121	145	4	19	M16	6.0	4.0	1.99	
(90)	101.6	102.6	190	14	-	-	-	-	2	131	155	4	19	M16	6.0	4.0	2.09	
100	114.3	115.4	200	16	-	-	-	-	2	141	165	8	19	M16	7.0	4.0	2.39	
125	139.8	141.2	235	16	-	-	-	-	2	176	200	8	19	M16	7.0	4.0	3.23	
150	165.2	166.6	265	18	-	-	-	-	2	206	230	8	19	M16	7.0	5.0	4.41	
(175)	190.7	192.1	300	18	-	-	-	-	2	232	260	8	23	M20	7.5	5.0	5.51	
200	216.3	218.0	320	20	-	-	-	-	2	252	280	8	23	M20	8.5	6.0	6.33	
(225)	241.8	243.7	345	20	-	-	-	-	2	277	305	12	23	M20	9.0	6.0	6.64	
250	267.4	269.5	385	22	-	-	-	-	2	317	345	12	23	M20	10.0	6.0	9.45	
300	318.5	321.0	430	22	-	-	-	-	3	360	390	12	23	M20	10.0	6.0	10.30	
350	355.6	358.1	480	24	-	-	-	-	3	403	435	12	25	M22	12.0	7.0	14.00	
400	406.4	409.0	540	24	-	-	-	-	3	463	495	16	25	M22	12.0	7.0	16.90	
450	457.2	460.0	605	24	40	495	500	5	3	523	555	16	25	M22	12.0	7.0	24.80	
500	508.0	511.0	655	24	40	546	552	5	3	573	605	20	25	M22	12.0	7.0	26.90	
550	558.8	562.0	720	26	42	597	603	5	3	630	665	20	27	M24	12.0	7.0	34.10	
600	609.6	613.0	770	26	44	648	654	5	3	680	715	20	27	M24	12.0	7.0	37.50	
650	660.4	664.0	825	26	48	702	708	5	3	735	770	24	27	M24	12.0	7.0	42.80	
700	711.2	715.0	875	26	48	751	758	5	3	785	820	24	27	M24	12.0	7.0	45.40	
750	762.0	766.0	945	28	52	802	810	5	3	840	880	24	33	M30	12.0	7.0	57.40	
800	812.8	817.0	995	28	52	854	862	5	3	890	930	24	33	M30	13.0	8.0	60.80	
850	863.6	868.0	1045	28	54	904	912	5	3	940	980	24	33	M30	13.0	8.0	63.50	
900	914.4	919.0	1095	30	56	956	964	5	3	990	1030	24	33	M30	13.0	8.0	75.30	
1000	1016.0	1021.0	1195	32	60	1058	1066	5	3	1090	1130	28	33	M30	14.0	9.0	88.50	
*(1100)	1117.6	1123.0	1305	32	-	-	-	-	3	1200	1240	28	33	M30	-	-	-	
*1200	1219.2	1225.0	1420	34	-	-	-	-	3	1305	1350	32	33	M30	-	-	-	
*1350	1371.6	-	1575	34	-	-	-	-	3	1460	1505	32	33	M30	-	-	-	
*1500	1524.0	-	1730	36	-	-	-	-	3	1615	1660	36	33	M30	-	-	-	

**Notes**

1. Flanges of parenthesized nominal diameter had letter not be used.
2. The facing of flanges shall conform to KS B1519 (JIS B2202) 1987.
3. Nominal diameter over 1000 is manufacturer's standard (\*)



## 10K KS B1503 / JIS B2220

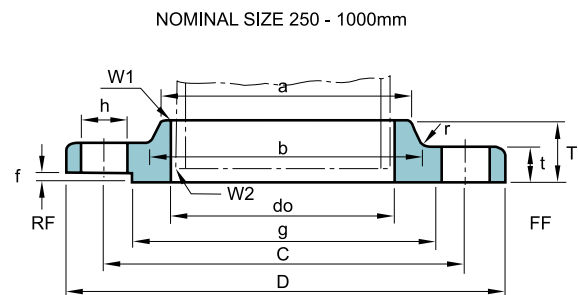
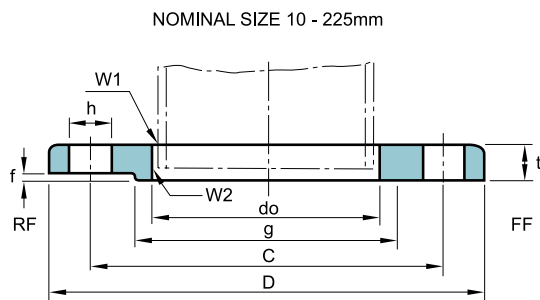

Unit : mm

Nominal Bore of Flange	Outside Dia. of Appli- Cable pipe	Inside Dia. of Flange	Outside Dia. of Flange	SECTIONAL DIMENSIONS OF FLANGE							DIA. OF BOLT				Welding		Weight (kg)
				t	T	Dia. of Hub		Radius	Raised Face	Dia. of Raised Face	Dia. of Bolt Circle	Number of Bolt Holes	Hole Dia.	Nominal Bolt Size	W1	W2	
						a	b										
10	17.3	17.8	90	12	-	-	-	-	1	46	65	4	15	M12	5.0	2.5	0.52
15	21.7	22.2	95	12	-	-	-	-	1	51	70	4	15	M12	5.0	3.0	0.57
20	27.2	27.7	100	14	-	-	-	-	1	56	75	4	15	M12	5.0	3.0	0.73
25	34.0	34.5	125	14	-	-	-	-	1	67	90	4	19	M16	5.0	3.0	1.13
32	42.7	43.2	135	16	-	-	-	-	2	76	100	4	19	M16	6.0	3.0	1.48
40	48.6	49.1	140	16	-	-	-	-	2	81	105	4	19	M16	6.0	3.0	1.56
50	60.5	61.1	155	16	-	-	-	-	2	96	120	4	19	M16	6.0	3.0	1.88
65	76.3	77.1	175	18	-	-	-	-	2	116	140	4	19	M16	6.5	4.0	2.60
80	89.1	90.0	185	18	-	-	-	-	2	126	150	8	19	M16	6.5	4.0	2.61
(90)	101.6	102.6	195	18	-	-	-	-	2	136	160	8	19	M16	6.5	4.0	2.76
100	114.3	115.4	210	18	-	-	-	-	2	151	175	8	19	M16	7.0	4.0	3.14
125	139.8	141.2	250	20	-	-	-	-	2	182	210	8	23	M20	7.5	4.0	4.77
150	165.2	166.6	280	22	-	-	-	-	2	212	240	8	23	M20	8.0	5.0	6.34
(175)	190.7	192.1	305	22	-	-	-	-	2	237	265	12	23	M20	9.0	5.0	6.82
200	216.3	218.0	330	22	-	-	-	-	2	262	290	12	23	M20	9.0	6.0	7.53
(225)	241.8	243.7	350	22	-	-	-	-	2	282	310	12	23	M20	9.0	6.0	7.74
250	267.4	269.5	400	24	36	288	292	6	2	324	355	12	25	M22	10.0	6.0	12.70
300	318.5	321.0	445	24	38	340	346	6	3	368	400	16	25	M22	10.0	6.0	13.80
350	355.6	358.1	490	26	42	380	386	6	3	413	445	16	25	M22	12.0	7.0	18.20
400	406.4	409.0	560	28	44	436	442	6	3	475	510	16	27	M24	12.0	7.0	25.20
450	457.2	460.0	620	30	48	496	502	6	3	530	565	20	27	M24	14.0	8.0	33.00
500	508.0	511.0	675	30	48	548	554	6	3	585	620	20	27	M24	14.0	8.0	37.60
550	558.8	562.0	745	32	52	604	610	6	3	640	680	20	33	M30	15.0	9.0	49.70
600	609.6	613.0	795	32	52	656	662	6	3	690	730	24	33	M30	16.0	10.0	52.60
650	660.4	664.0	845	34	56	706	712	6	3	740	780	24	33	M30	16.0	10.0	60.60
700	711.2	715.0	905	34	58	762	770	6	3	800	840	24	33	M30	17.0	10.0	70.60
750	762.0	766.0	970	36	62	816	824	6	3	855	900	24	33	M30	18.0	11.0	85.80
800	812.8	817.0	1020	36	64	868	876	6	3	905	950	28	33	M30	19.0	12.0	91.20
(850)	863.6	868.0	1070	36	66	920	928	6	3	955	1000	28	33	M30	19.0	12.0	98.60
900	914.4	919.0	1120	38	70	971	979	6	3	1005	1050	28	33	M30	22.0	14.0	109.00
1000	1016.0	1021.0	1235	40	74	1073	1081	6	3	1110	1160	28	39	M36	22.0	14.0	133.00
*(1100)	1117.6	1123.0	1345	42	76	-	-	-	3	1220	1270	28	39	M36	-	-	-
*1200	1219.2	1225.0	1465	44	78	-	-	-	3	1325	1380	32	39	M36	-	-	-
*1350	1371.6	-	1630	48	82	-	-	-	3	1480	1540	36	45	M42	-	-	-
*1500	1524.0	-	1795	50	90	-	-	-	3	1635	1700	40	45	M42	-	-	-

**Notes**

1. Flanges of parenthesized nominal diameter had letter not be used.
2. The facing of flanges shall conform to KS B1519 (JIS B2202) 1987.
3. Nominal diameter over 1000 is manufacturer's standard (\*)

# 16K KS B1503 / JIS B2220

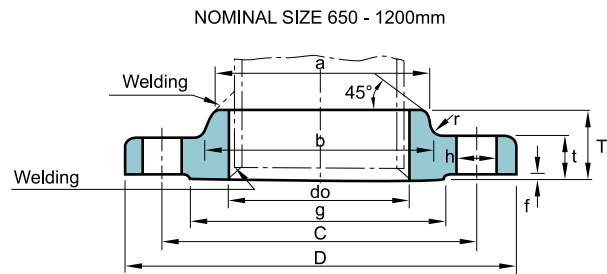
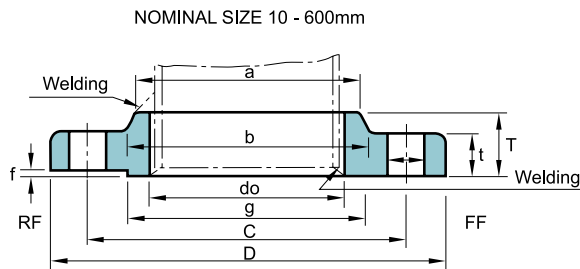

Unit : mm

Nominal Bore of Flange	Outside Dia. of Steel pipe	Inside Dia. of Flange	Outside Dia. of Flange	SECTIONAL DIMENSIONS OF FLANGE							DIA. OF BOLT			Nominal Bolt Size	Weight (kg)
				t	T	Dia. of Hub		Radius	f	g	Bolt Circle Dia.	Number of Bolt Holes	Hole Dia.		
						a	b								
10	17.3	17.8	90	12	16	26	28	4	1	46	65	4	15	M12	0.52
15	21.7	22.2	95	12	16	30	32	4	1	51	70	4	15	M12	0.58
20	27.2	27.7	100	14	20	38	42	4	1	56	75	4	15	M12	0.75
25	34.0	34.5	125	14	20	46	50	4	1	67	90	4	19	M16	1.16
32	42.7	43.2	135	16	22	56	60	5	2	76	100	4	19	M16	1.53
40	48.6	49.1	140	16	24	62	66	5	2	81	105	4	19	M16	1.64
50	60.5	61.1	155	16	24	76	80	5	2	96	120	8	19	M16	1.83
65	76.3	77.1	175	18	26	94	98	5	2	116	140	8	19	M16	2.58
80	89.1	90.0	200	20	28	108	112	6	2	132	160	8	23	M20	3.66
(90)	101.6	102.6	210	20	30	120	124	6	2	145	170	8	23	M20	3.95
100	114.3	115.4	225	22	34	134	138	6	2	160	185	8	23	M20	4.94
125	139.8	141.2	270	22	34	164	170	6	2	195	225	8	25	M22	7.00
150	165.2	166.6	305	24	38	196	202	6	2	230	260	12	25	M22	9.62
200	216.3	218.0	350	26	40	244	252	6	2	275	305	12	25	M22	12.10
250	267.4	269.5	430	28	44	304	312	6	2	345	380	12	27	M24	20.00
300	318.5	321.0	480	30	48	354	364	8	3	395	430	16	27	M24	24.40
350	355.6	358.1	540	34	52	398	408	8	3	440	480	16	33	M30X3	35.00
400	406.4	409.0	605	38	60	446	456	10	3	495	540	16	33	M30X3	46.20
450	457.2	460.0	675	40	64	504	514	10	3	560	605	20	33	M30X3	61.90
500	508.0	511.0	730	42	68	558	568	10	3	615	660	20	33	M30X3	73.25
(550)	558.8	562.0	795	44	70	612	622	10	3	670	720	20	39	M36X3	88.10
600	609.6	613.0	845	46	74	666	676	10	3	720	770	24	39	M36X3	98.80
(650)	660.4	664.0	895	48	77	704	726	10	5	770	820	24	39	M36X3	101.00
700	711.2	715.0	960	50	80	754	776	10	5	820	875	24	42	M39X3	120.00
(750)	762.0	766.0	1020	52	83	806	832	10	5	880	935	24	42	M39X3	141.00
800	812.8	817.0	1085	54	86	865	885	10	5	930	990	24	48	M45X3	161.00
(850)	863.6	868.0	1135	56	89	916	936	10	5	980	1040	24	48	M45X3	177.00
900	914.4	919.0	1185	58	93	968	986	10	5	1030	1090	28	48	M45X3	191.00
1000	1016.0	1021.0	1320	62	99	1070	1098	12	5	1140	1210	28	56	M52X3	230.00
(1100)	1117.6	1123.0	1420	66	105	1180	1200	12	5	1240	1310	32	56	M52X3	289.00
1200	1219.2	1225.0	1530	70	112	1282	1302	12	5	1350	1420	32	56	M52X3	348.00

**Notes**

1. Flanges of parenthesized nominal diameter had letter not be used.
2. The facing of flanges shall conform to KS B1519 (JIS B2202) 1987.
3. The dimension of flange of 650A and larger in nominal sizes excluding 850A, are in accordance with the nominal pressure 25 BAR specified in ISO2084-1974



20K KS B1503 / JIS B2220

TYPE A  
NOMINAL SIZE 10 - 50mm

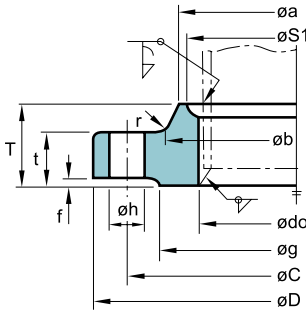

TYPE B  
NOMINAL SIZE 10 - 50mm

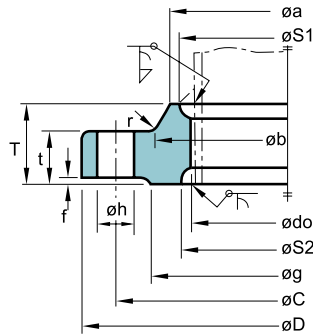

TYPE C  
NOMINAL SIZE 65 - 600mm

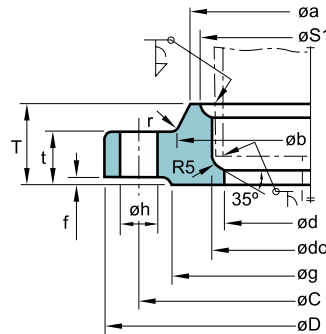

Unit : mm

Nominal Bore of Flange	Outside Dia. of Steel pipe	Inside Dia. of Flange	Outside Dia. of Flange	SECTIONAL DIMENSIONS OF FLANGE										BOLT HOLE			Nominal Bolt Size	REFERENCE					Weight (kg)
				t	T	Dia. of Hub		Ra- dius	f	g	d	Bolt Circle Dia.	Number of Bolt Holes	Hole Dia. h	S1	m		S2	n	l			
						a	b														C		
10	17.3	17.8	90	14	20	30	32	4	1	46	-	65	4	15	M12	27	4	27	4	-	0.59		
15	21.7	22.2	95	14	20	34	36	4	1	51	-	70	4	15	M12	31	4	31	4	-	0.65		
20	27.2	27.7	100	16	22	40	42	4	1	56	-	75	4	15	M12	37	4	37	4	-	0.81		
25	34.0	34.5	125	16	24	48	50	4	1	67	-	90	4	19	M16	44	4	44	4.5	-	1.29		
32	42.7	43.2	135	18	26	56	60	5	2	76	-	100	4	19	M16	52	4	53	5	-	1.60		
40	48.6	49.1	140	18	26	62	66	5	2	81	-	105	4	19	M16	58	4	59	5.5	-	1.69		
50	60.5	61.1	155	18	26	76	80	5	2	96	-	120	8	19	M16	70	4	72	5.5	-	1.89		
65	76.3	77.7	175	20	30	100	104	5	2	116	65.9	140	8	19	M16	94	6	-	-	6	2.60		
80	89.1	90.0	200	22	34	113	117	6	2	132	78.1	160	8	23	M20	107	6	-	-	6	3.93		
(90)	101.6	102.6	210	24	36	126	130	6	2	145	90.2	170	8	23	M20	120	6	-	-	6	4.56		
100	114.3	115.4	225	24	36	138	142	6	2	160	102.3	185	8	23	M20	132	6	-	-	6	5.13		
125	139.8	141.2	270	26	40	166	172	6	2	195	126.6	225	8	25	M22	160	7	-	-	6	8.30		
150	165.2	166.6	305	28	42	196	202	6	2	230	151.0	260	12	25	M22	186	8	-	-	6	10.60		
200	216.3	218.0	350	30	46	244	252	6	2	275	199.9	305	12	25	M22	237	9	-	-	6	13.30		
250	267.4	269.5	430	34	52	304	312	6	2	345	248.8	380	12	27	M24	290	10	-	-	6	23.40		
300	318.5	321.0	480	36	56	354	364	8	3	395	297.9	430	16	27	M24	345	11	-	-	6	27.70		
350	355.6	358.1	540	40	62	398	408	8	3	440	333.4	480	16	33	M30X3	384	12	-	-	6	39.20		
400	406.4	409.0	605	46	70	446	456	10	3	495	381.0	540	16	33	M30X3	437	13	-	-	7	54.20		
450	457.2	460.0	675	48	78	504	514	10	3	560	431.8	605	20	33	M30X3	490	15	-	-	7	71.70		
500	508.0	511.0	730	50	84	558	568	10	3	615	482.6	660	20	33	M30X3	544	16	-	-	7	86.20		
(550)	558.8	562.0	795	52	90	612	622	10	3	670	533.4	720	20	39	M36X3	595	16	-	-	7	105.00		
600	609.6	613.0	845	54	96	666	676	10	3	720	584.2	770	24	39	M36X3	646	18	-	-	7	119.00		
*650	660.4	664.0	945	60	-	-	-	-	5	790	-	850	24	48	M45X3	-	-	-	-	-	-		
*700	711.2	715.0	995	64	-	-	-	-	5	840	-	900	24	48	M45X3	-	-	-	-	-	-		
*750	762.0	766.0	1080	68	-	-	-	-	5	900	-	970	24	56	M52X3	-	-	-	-	-	-		
*800	812.8	817.0	1140	72	-	-	-	-	5	960	-	1030	24	56	M52X3	-	-	-	-	-	-		
*850	863.6	868.0	1200	74	-	-	-	-	5	1020	-	1090	24	56	M52X3	-	-	-	-	-	-		
*900	914.4	919.0	1250	76	-	-	-	-	5	1070	-	1140	28	56	M52X3	-	-	-	-	-	-		

Notes

- Flanges of parenthesized nominal diameter had letter not be used.
- "d" is an example of pipe thickness for schedule 40 for nominal diameter 400 and under, and for schedule 12.7 mm for 450 through 600 of KS D3562 and KS D3507 (JIS G3454, JIS G3456)
- The dimension of the notch (m, n, S1, S2) for welding can decided between conerned parties.
- Nominal diameter over 600 is manufacturer's standard (\*)

## 30K KS B1503 / JIS B2220

NOMINAL SIZE 10 - 50mm (TYPE B)

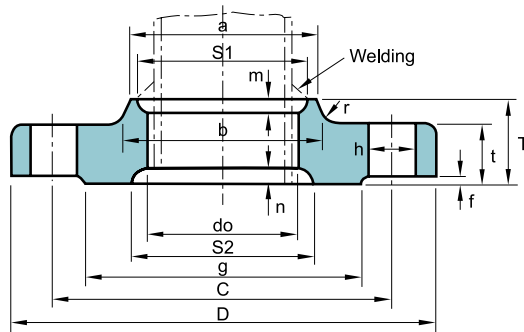

NOMINAL SIZE 65 - 400mm (TYPE C)

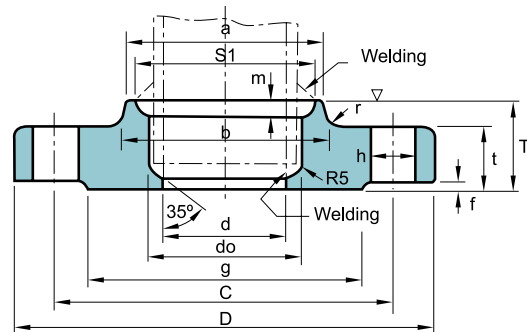

Unit : mm

Nominal Bore of Flange	Outside Dia. of Steel pipe	Inside Dia. of Flange	Outside Dia. of Flange	SECTIONAL DIMENSIONS OF FLANGE								BOLT HOLE			Nominal Bolt Size	REFERENCE					Weight (kg)
				t	T	Dia. of Hub		Ra- dius	f	g	d	Bolt Circle Dia.	Number of Bolt Holes	Hole Dia.		S1	m	S2	n	l	
						a	b														
10	17.3	17.8	110	16	24	30	34	4	1	52	-	75	4	19	M16	-	-	-	-	0.99	
15	21.7	22.2	115	18	26	36	40	5	1	55	-	80	4	19	M16	31	4.0	40	5	1.23	
20	27.2	27.7	120	18	28	42	46	5	1	60	-	85	4	19	M16	37	5.0	44	5	1.34	
25	34.0	34.5	130	20	30	50	54	5	1	70	-	95	4	19	M16	55	6.0	52	5	1.76	
32	42.7	43.2	140	22	32	60	64	6	2	80	-	105	4	19	M16	52	6.0	60	5	2.15	
40	48.6	49.1	160	22	34	66	70	6	2	90	-	120	4	23	M20	58	6.0	66	5	2.82	
50	60.5	61.1	165	22	36	82	86	6	2	105	-	130	8	19	M16	70	6.5	78	5	2.89	
65	76.3	77.1	200	26	40	102	106	8	2	130	65.9	160	8	23	M20	96	9.5	94	5	4.70	
80	89.1	90.0	210	28	44	115	121	8	2	140	78.1	170	8	23	M20	109	9.5	-	6	5.36	
(90)	101.6	102.6	230	30	46	128	134	8	2	150	90.2	185	8	25	M22	122	9.5	-	6	6.85	
100	114.3	115.4	240	32	48	141	147	8	2	160	102.3	195	8	25	M22	135	9.5	-	6	7.89	
125	139.8	141.2	275	36	54	166	172	8	2	195	126.6	230	8	25	M22	160	9.5	-	6	11.40	
150	165.2	166.6	325	38	58	196	204	8	2	235	151.0	275	12	27	M24	186	9.5	-	6	16.70	
200	216.3	218.0	370	42	64	248	256	8	2	280	199.9	320	12	27	M24	237	9.5	-	6	20.60	
250	267.4	269.5	450	48	72	306	314	10	2	345	248.8	390	12	22	M30	290	10.0	-	6	36.10	
300	318.5	321.0	515	52	78	360	370	10	3	405	297.9	450	16	33	M30	345	12.0	-	6	49.90	
350	355.6	358.1	560	54	84	402	412	12	3	450	333.4	495	16	33	M30	383	13.0	-	6	61.20	
400	406.4	409.0	630	60	92	456	468	15	3	510	381.0	560	16	39	M36	435	14.0	-	7	85.20	

**Notes**

- Flanges of parenthesized nominal diameter had letter not be used.
- "d" is an example of pipe thickness for schedule 40 of KS D3562 and KS D3507 (JIS G3454, JIS G3456). if required, purchaser can specify for other pipe wall thickness.
- This dimension of bolt holes (h) shall be in accordance with Class 3 of KS B1007 (Grade 3 of JIS B1001) where the nominal designation of screw thread of bolt is not more than M16, and in accordance with Class 2 of KS B1007 (Grade 2 of JIS B1001) where the nominal designation of screw thread of bolt is not less than M30 × 3.
- The dimension of the notch (m, n, S1, S2) for welding can be decided between concerned parties agreement between parties concerned.

## 210Kgf/cm<sup>2</sup> (JIS B2291 SQUARE FLANGES)

Flange for Oil Pressure

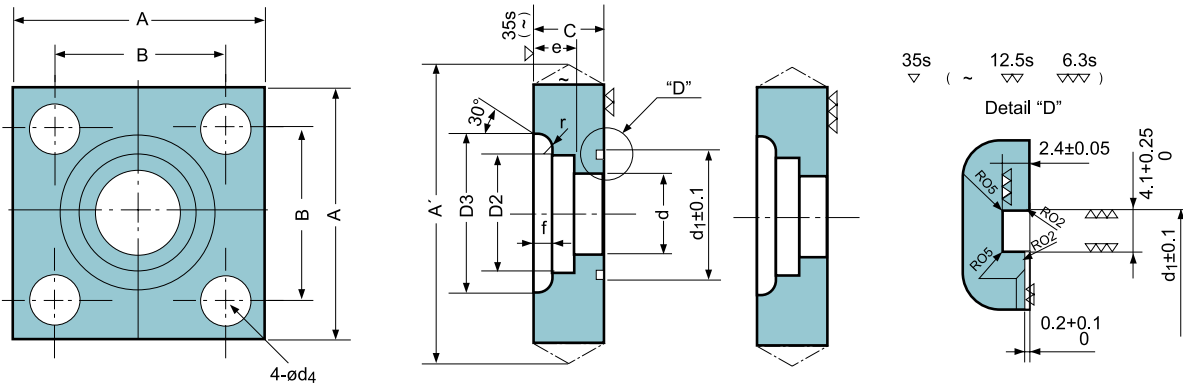

Unit : mm

Nominal Bore	A	A' (Max)	B	C	d	d1	d2	e	d3	d4	f	r	Weight (kg)	G 계열 O 링			
15	63	±1.0	67	40	22	0	16.0	30	22.2	+0.2	11	32	11	3.5	5	0.6	G25
20	68		72	45													
25	80	±1.2	85	53	28	0	25.0	40	34.5	14	45	13	4.0	5	1.2	G35	
32	90		95	63													28
40	100	±1.5	106	70	36	0	37.5	55	49.1	0	18	63	18	7.0	5	2.4	G50
50	112		118	80													
65	140	±2.0	148	100	45	-2	60.0	80	77.1	+0.4	22	95	22	9.5	6	5.3	G75
80	155		163	112													

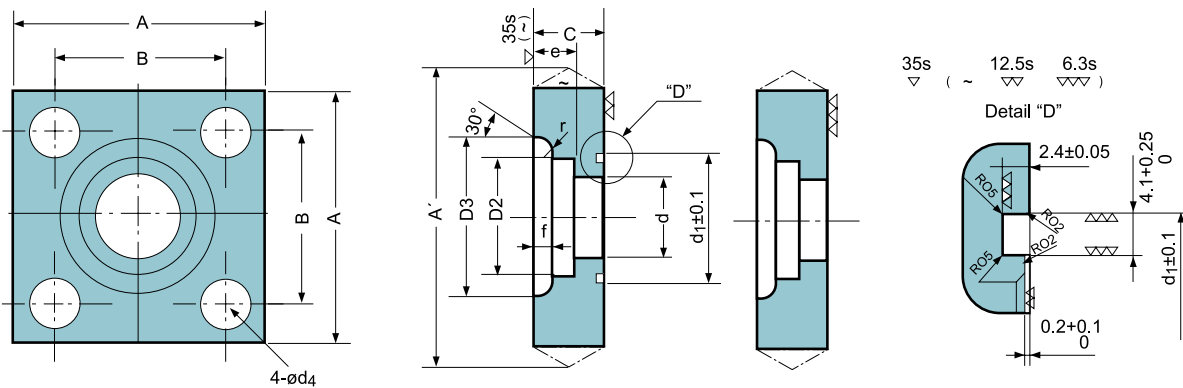

Unit : mm

Nominal Bore	A	A' (Max)	B	C	d	d1	d2	e	d3	d4	f	r	Weight (kg)			
15	54	±1.0	58	36	22	0	16.0	30	22.2	+0.2	11	32	11	3.5	5	0.5
20	58		62	40												
25	68	±1.2	73	48	28	0	25.0	40	34.5	14	45	13	4.0	5	0.8	
32	76		81	56												28
40	92	±1.5	98	65	36	0	37.5	55	49.1	0	18	63	18	7.0	5	1.9
50	100		106	73												
65	128	±2.0	136	92	45	-2	60.0	80	77.1	+0.4	22	95	22	9.5	6	4.1
80	140		148	103												

# PRODUCT RANGE

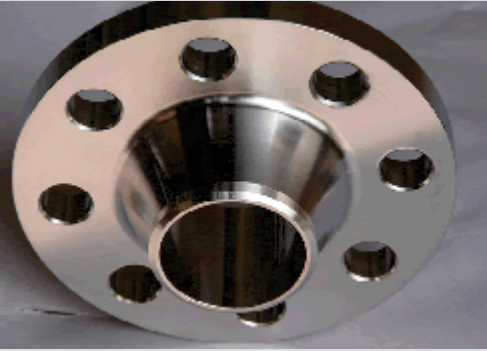

## Welding Neck Flanges:

are flanges that designed to be joined to a piping system by butt welding. This kind of flange include lots of specification, Weld neck Flange is expensive because of its long neck and cost of people for contact WN flange with pipeline or fitting, but is preferred for high stress applications. The bore of Weld-Neck flange matches bore of the pipeline, reducing turbulence and erosion.

## Slip-on Flanges:

are slipped over the pipe and welded to provide strength and prevent leakage. Slip on Flanges are at the low cost end of the scale, and do not require high accuracy when cutting the pipe to length. These slip on can sometimes have a boss or hub, and can be made with a bore to suit either pipe or tube.

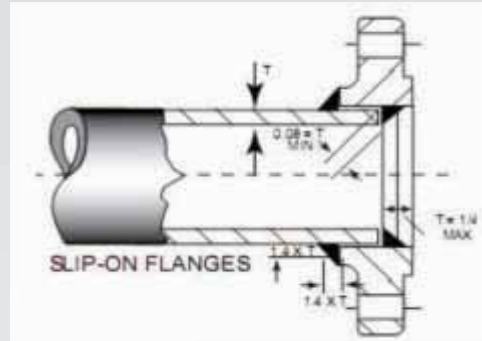

## Screwed or Threaded Flanges:

(Screwed flanges) are similar to slip-on flanges in outline, but the bore is threaded, thus enabling assembly without welding. This obviously limits its application to relatively low pressure piping systems. Threaded Flanges may be welded around the joint after assembly, but this is not considered a satisfactory method of increasing the flanges' pressure applications. Threaded flange use in low press condition usually.

## Lap Joint or Van Stone Flanges:

(LJ Flanges) or Loose flange (LF flange) called are used on piping fitted with lapped pipe or with lap joint stub ends the combined initial cost of the two items being approximately one-third higher than that of comparable welding neck flanges. Their pressure-holding ability is little, Lap Joint flanges have certain special advantages: Freedom to swivel around the pipe facilitates the lining up of opposing flange bolt holes. Lack of contact with the fluid in the pipe often permits the use of inexpensive carbon steel flanges with corrosion resistant pipe. In systems which erode or corrode quickly, the flanges may be salvaged for re-use.



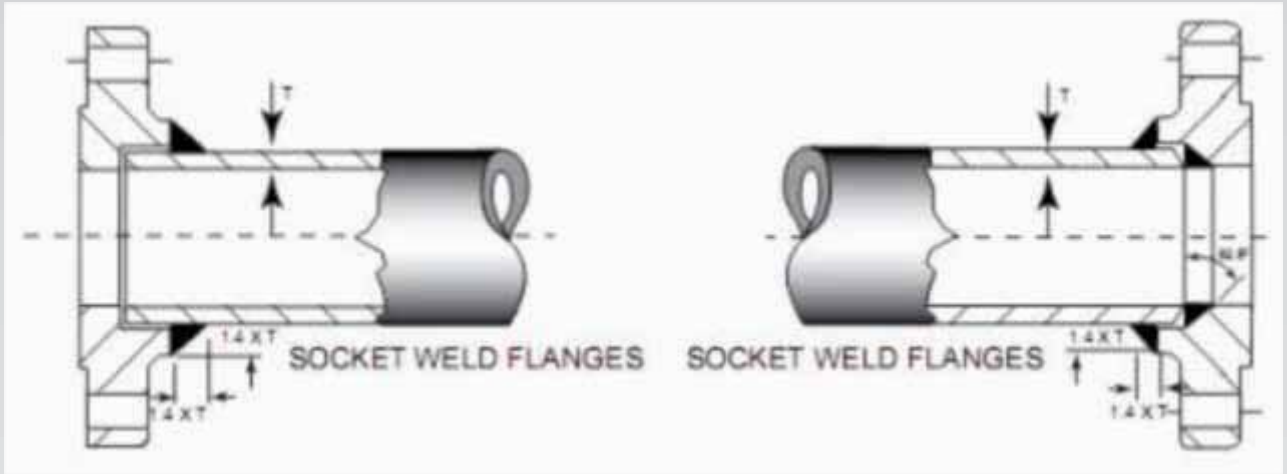

### Socket-Welding Flanges:

forged flange is similar to the slip-on flange, same to socket welding flange, but the bore is counter-bored to accept pipe. The diameter of the remaining bore is the same as the inside diameter of the pipe. The Socket Welding Flange is attached to the pipe by a fillet weld around the hub of the flange. An optional internal weld may be applied in high stress applications. The biggest use of Socket Flanges is in high pressure systems such as hydraulic and steam lines.

### Blind Flanges:

include lots of kinds, which has no bore, and is used to close piping system. When you open a piping system and Blind flange also permits easy access to a line once it has been closed. The low pressure pipe system be contacted by threaded / screwed.



### Custom Flange:

We are the capable and have capacity to make any Custom Designed flange and fittings according to customer's requirements.



# FLANGES

- SLIP ON FLANGES
- BLIND FLANGES
- WELD FLANGES



## DIN 2543 SLIP - ON FLANGES DIN 2527 BLIND FLANGES DIN 2633 WELDING NECK FLANGES

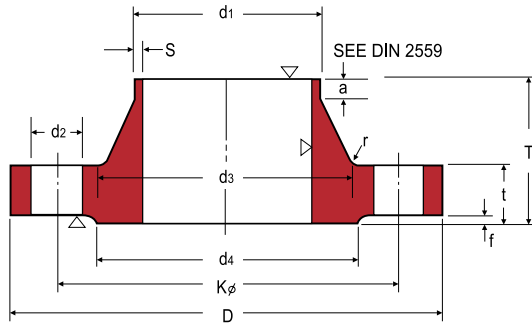

WELDING NECK

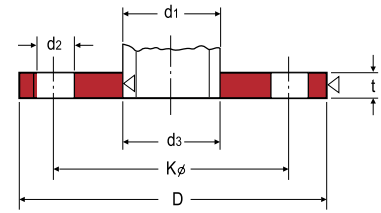

SLIP-ON/PLATE

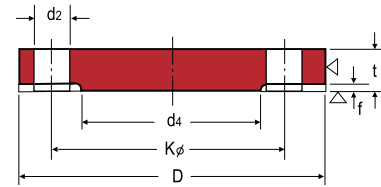

BLIND

Unit:mm

Nominal Bore	Bore		Common Dimension				Hub				Raised Face		Drilling			Approx.Weight(kg)			
	d <sub>1</sub>	D	t			K	T	d <sub>3</sub>	s	r	a	d <sub>4</sub>	f	Number of Bolt	Dia. of Bolt	d <sub>2</sub>	DIN 2633	DIN 2543	
			Welding Neck	Slip-on (no-hub)	Blind					≈									
10	14 17.2°)	90	14	14	14	60	35	25 28	1.8	4	6	40	2	4	M12	(1/2")	14	0.63	0.580
15	20 21.3°)	95	14	14	14	65	35	30 32	2.0	4	6	45	2	4	M12	(1/2")	14	0.72	0.648
20	25 26.9°)	105	16	16	16	75	38	38 40	2.3	4	6	58	2	4	M12	(1/2")	14	1.01	0.952
25	30 33.7°)	115	16	16	16	85	38	42 45	2.6	4	6	68	2	4	M12	(1/2")	14	1.23	1.14
32	38 42.4°)	140	16	16	16	100	40	52 56	2.6	6	6	78	2	4	M16	(5/8")	18	1.80	1.69
40	44.5 48.3°)	150	16	16	16	110	42	60 64	2.6	6	7	88	3	4	M16	(5/8")	18	2.09	1.86
50	57 60.3°)	165	18	18	18	125	45	72 75	2.9	6	8	102	3	4	M16	(5/8")	18	2.88	2.53
65	76.1°)	185	18	18	18	145	45	90	2.9	6	10	122	3	4	M16	(5/8")	18	3.66	3.06
80	88.9°)	200	20	20	20	160	50	105	2.2	8	10	138	3	8	M16	(5/8")	18	4.77	3.70
100	108 114.3°)	220	20	20	20	180	52	125 131	3.6	8	12	158	3	8	M16	(5/8")	18	5.65	4.62
125	133 139.7°)	250	22	22	22	210	55	150 156	4.0	8	12	188	3	8	M16	(5/8")	18	8.42	6.30
150	159 168.3°)	285	22	22	22	240	55	175 184	4.5	10	12	212	3	8	M20	(3/4")	23	10.4	7.75
200	216 219.1°)	340	24	24	24	295	62	232 235	5.9	10	16	268	3	12	M20	(3/4")	23	16.1	11.0
250	267 273°)	405	26	26	26	355	70	285 292	6.3	12	16	320	3	12	M24	(7/8")	27	24.9	15.6
300	318	460	28	28	28	410	78	338 344	7.1	12	16	378	4	12	M24	(7/8")	27	35.1	22.0
350	355.6°)	520	30	30	30	470	82	390	8.0	12	16	438	4	16	M24	(7/8")	27	47.8	28.7
400	406.4°)	580	32	32	32	525	85	445	8.0	12	16	490	4	16	M27	(1")	30	63.5	36.3
500	419 508°)	715	34	36	34	650	90	548	8.0	12	16	610	4	20	M30	(1 1/8")	33	102.0	59.3
600	609.6°)	840	36	40	-	770	95	652	8.8	12	18	725	5	20	M33	(1 1/4")	36	-	-
700	711.2°)	910	36	-	-	840	100	755	8.8	12	18	795	5	24	M33	(1 1/4")	36	-	-
800	720 812.8°)	1025	38	-	-	950	105	855	10.0	12	20	900	5	24	M36	(1 3/8")	39	-	-
900	820 914.4°)	1125	40	-	-	1050	110	955	10.0	12	20	1000	5	28	M36	(1 3/8")	39	-	-
1000	920 1016°)	1255	42	-	-	1170	120	1058	10.0	16	20	1115	5	28	M39	(1 1/2")	42	-	-

Notes : Out side diameter of pipe complies with ISO recommendation R64

## DIN 2544 SLIP - ON FLANGES DIN 2527 BLIND FLANGES DIN 2634 WELDING NECK FLANGES

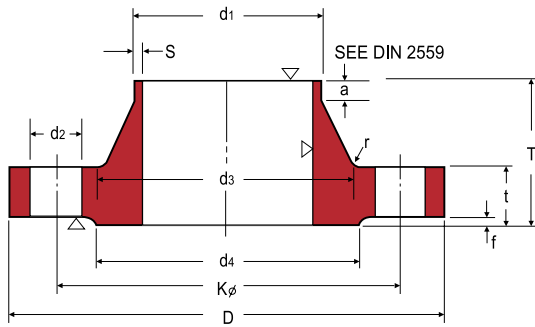

WELDING NECK

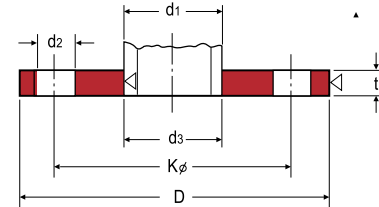

SLIP-ON/PLATE

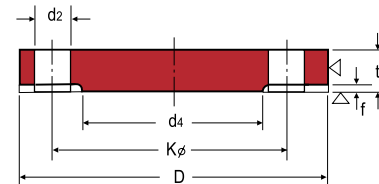

BLIND

Unit:mm

Nominal Bore	Bore		Common Dimension					Hub				Raised Face		Drilling			Approx.Weight(kg)		
	d <sub>1</sub>	D	t			K	T	d <sub>3</sub>	s	r	a ≈	d <sub>4</sub>	f	Nominal of Bolt	Dia. of Bolt	d <sub>2</sub>	DIN 2632	DIN 2576	
			Welding Neck	Slip-on	Blind														
10	14 17.2*)	90	16	16	16	60	35	25 28	1.8	4	6	40	2	4	M12	(1/2")	14	0.72	0.6610
15	20 21.3*)	95	16	16	16	65	38	30 32	2.0	4	6	45	2	4	M12	(1/2")	14	0.81	.746
20	25 26.9*)	105	18	18	18	75	40	38 40	2.3	4	6	58	2	4	M12	(1/2")	14	1.24	1.06
25	30 33.7*)	115	18	18	18	85	40	42 46	2.6	4	6	68	2	4	M12	(1/2")	14	1.38	1.29
32	38 42.4*)	140	18	18	18	100	42	52 56	2.6	6	6	78	2	4	M16	(5/8")	18	2.03	1.88
40	44.5 48.3*)	150	18	18	18	110	45	60 64	2.6	6	7	88	3	4	M16	(5/8")	18	2.35	2.34
50	57 60.3*)	165	20	20	20	125	48	72 75	2.9	6	8	102	3	4	M16	(5/8")	18	3.20	2.82
65	76.1*)	185	22	22	22	145	52	90	2.9	6	10	122	3	8	M16	(5/8")	18	4.29	3.74
80	88.9*)	200	24	24	24	160	58	105	3.2	8	12	138	3	8	M16	(5/8")	18	5.88	4.75
100	108 114.3*)	235	24	24	24	190	65	128 134	3.6	8	12	162	3	8	M20	(3/4")	23	7.54	6.52
125	133 139.7*)	270	26	26	26	220	68	155 162	4.0	8	12	188	3	8	M24	(7/8")	27	10.8	9.07
150	159 168.3*)	300	28	28	28	250	75	182 192	4.5	10	12	218	3	8	M24	(7/8")	27	14.5	11.8
200	216 219.1*)	360	30	30	30	310	80	240 244	6.3	10	16	278	3	12	M24	(7/8")	27	22.3	17.0
250	267 273*)	425	32	32	32	370	88	292 298	7.1	12	18	335	3	12	M27	(1")	30	33.5	24.4
300	318	485	34	34	34	430	92	345 352	8.0	12	18	395	4	16	M27	(1")	30	46.3	31.2
350	355.6*) 368	555	38	38	38	490	100	398	8.0	12	20	450	4	16	M30	(1 1/4")	33	68.0	45.0
400	406.4*) 419	620	40	40	40	550	110	452	8.8	12	20	505	4	16	M33	(1 1/4")	36	89.7	58.7
500	508*) 521	730	44	44	44	660	125	558	10.0	12	20	615	4	20	M33	(1 1/4")	36	138.0	86.1
600	609.6*) 622	845	46	-	-	770	125	660	11.0	12	20	720	5	20	M36	(1 3/8")	39	-	101.0
700	711.2*) 720	960	46	-	-	875	125	760	12.5	12	20	820	5	24	M39	(1 1/2")	42	-	134.0
800	812.8*) 820	1085	50	-	-	990	135	865	14.2	12	22	930	5	24	M45	(1 3/4")	48	-	183.0
900	914.4*) 920	1185	54	-	-	1090	145	968	16.0	12	24	1030	5	28	M45	(1 3/4")	48	-	232.0
1000	1016*) 1020	1320	58	-	-	1210	155	1070	17.5	16	24	1140	5	28	M52	(2")	56	-	302.0

Notes : Out side diameter of pipe complies with ISO recommendation R64

## DIN 2545 SLIP - ON FLANGES DIN 2527 BLIND FLANGES DIN 2635 WELDING NECK FLANGES

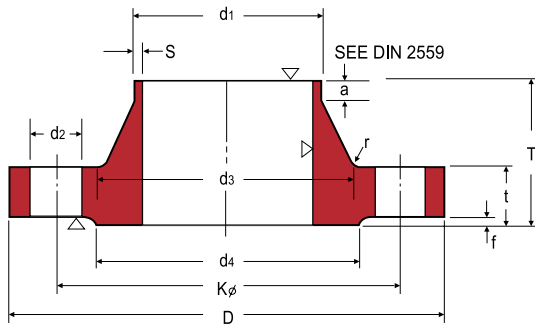

WELDING NECK

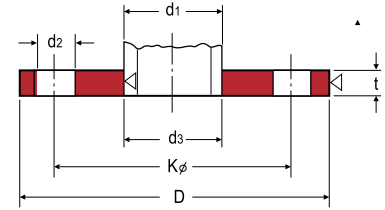

SLIP-ON/PLATE

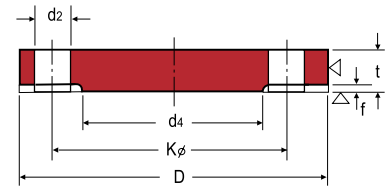

BLIND

Unit:mm

Nominal Bore	Bore		Common Dimension				Hub				Raised Face		Drilling			Approx.Weight(kg)			
	d <sub>1</sub>	D	t			K	T	d <sub>3</sub>	s	r	a	d <sub>4</sub>	f	Number of Bolt	Dia. of Bolt	d <sub>2</sub>	DIN 2545	DIN 2635	
			Welding Neck	Slip-on (no-hub)	Blind				≈										
10	14 17.2 <sup>*</sup>	90	16	16	16	60	35	25 28	1.8	4	6	40	2	4	M12	(1/2")	14	0.72	0.661
15	20 21.3 <sup>*</sup>	95	16	16	16	65	38	30 32	2.0	4	6	45	2	4	M12	(1/2")	14	0.81	0.746
20	25 26.9 <sup>*</sup>	105	18	18	18	75	40	38 40	2.3	4	6	58	2	4	M12	(1/2")	14	1.24	1.06
25	30 33.7 <sup>*</sup>	115	18	18	18	85	40	42 46	2.6	4	6	68	2	4	M12	(1/2")	14	1.38	1.29
32	38 42.4 <sup>*</sup>	140	18	18	18	100	42	52 56	2.6	6	6	78	2	4	M16	(5/8")	18	2.03	1.88
40	44.5 48.3 <sup>*</sup>	150	18	18	18	110	45	60 64	2.6	6	7	88	3	4	M16	(5/8")	18	2.35	2.33
50	57 60.3 <sup>*</sup>	165	20	20	20	125	48	72 75	2.9	6	8	102	3	4	M16	(5/8")	18	3.20	2.82
65	76.1 <sup>*</sup>	185	22	22	22	145	52	90	2.9	6	10	122	3	8	M16	(5/8")	18	4.29	3.74
80	88.9 <sup>*</sup>	200	24	24	24	160	58	105	3.2	8	12	138	3	8	M16	(5/8")	18	5.88	4.75
100	108 114.3 <sup>*</sup>	235	24	24	24	190	65	128 134	3.6	8	12	162	3	8	M20	(3/4")	23	7.54	6.52
125	133 139.7 <sup>*</sup>	270	26	26	26	220	68	155 162	4.0	8	12	188	3	8	M24	(7/8")	27	10.8	9.07
150	159 168.3 <sup>*</sup>	300	28	28	28	250	75	182 192	4.5	10	12	218	3	8	M24	(7/8")	27	14.5	11.80
(175)	(191) (193.7 <sup>*</sup> )	350	32	32	32	295	82	215 218	5.6	10	15	260	3	12	M27	(1")	30	22.1	18.2
200	216 219.1 <sup>*</sup>	375	34	34	34	320	88	240 244	6.3	10	16	285	3	12	M27	(1")	30	27.2	21.5
250	267 273 <sup>*</sup>	450	38	38	38	385	105	298 306	7.1	12	18	345	3	12	M30	(1 1/8")	33	43.8	34.9
300	318 323.9 <sup>*</sup>	515	42	42	42	450	115	352 362	8.0	12	18	410	4	16	M30	[1 1/8"]	33	63.3	49.7
350	355.6 <sup>*</sup> 368	580	46	46	46	510	125	408	8.8	12	20	465	4	16	M33	[1 1/4"]	36	89.5	68.1
400	406.4 <sup>*</sup> 419	660	50	50	50	585	135	462	11.0	12	20	535	4	16	M36	(1 3/8")	39	127.0	96.5
500	508 <sup>*</sup> 521	755	52	52	52	670	140	562	14.2	12	20	615	4	20	M39	(1 1/2")	42	172.0	117.0

Notes : Out side diameter of pipe complies with ISO recommendation R64

## DIN 2573 SLIP - ON FLANGES DIN 2527 BLIND FLANGES DIN 2631 WELDING NECK FLANGES

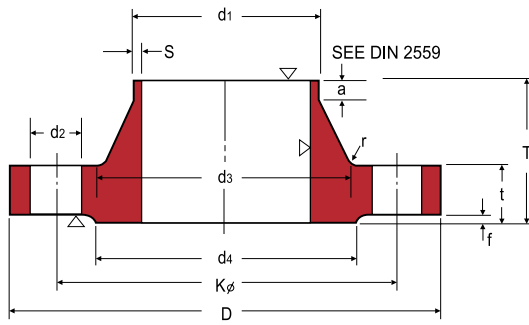

WELDING NECK

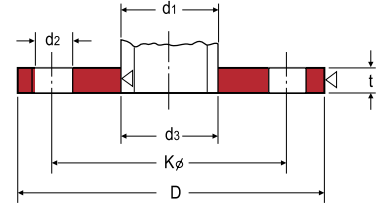

SLIP-ON/PLATE

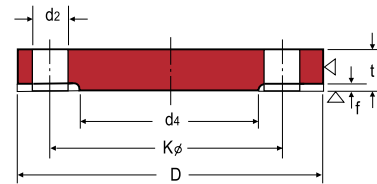

BLIND

Unit:mm

Nominal Bore	Bore d <sub>1</sub>	Common Dimension D	t				Hub					Raised Face		Drilling			Approx.Weight(kg)		
			Welding Neck	Slip-on	Blind	K	T	d <sub>3</sub>	s	r	a ≈	d <sub>4</sub>	f	Number of Bolt	Dia. of Bolt	d <sub>2</sub>	DIN 2631	DIN 2573	
10	14 (17.2°)	75	12	12	12	50	28	22 26	1.8	4	6	35	2	4	M10	-	11.5	0.036	0.325
15	20 (21.3°)	80	12	12	12	55	30	28 30	2.0	4	6	40	2	4	M10	-	11.5	0.410	0.392
20	25 (26.9°)	90	14	14	14	65	32	35 38	2.3	4	6	50	2	4	M10	-	11.5	0.600	0.592
25	30 (33.7°)	100	14	14	14	75	35	40 42	2.6	4	6	60	2	4	M10	-(1/2")	11.5	0.740	0.747
32	38 (42.4°)	120	14	16	14	90	35	50 55	2.6	6	6	70	2	4	M12	(1/2")	14	1.19	1.05
40	44.5 (48.3°)	130	14	16	14	100	38	58 62	2.6	6	7	80	3	4	M12	(1/2")	14	1.39	1.18
50	57 (60.3°)	140	14	16	14	110	38	70 74	2.9	6	8	90	3	4	M12	(1/2")	14	1.53	1.34
65	76.1°	160	14	16	14	130	38	88	2.9	6	9	110	3	4	M12	(5/8")	14	1.89	1.67
80	88.9°	190	16	18	16	150	42	102	3.2	8	10	128	3	4	M16	(5/8")	18	2.98	2.71
100	108 (114.3°)	210	16	18	16	170	45	122 130	3.6	8	10	148	3	4	M16	(5/8")	18	3.46	3.24
125	133 (139.7°)	240	18	20	18	200	48	148 155	4.0	8	10	178	3	8	M16	(5/8")	18	4.60	4.49
150	159 (168.3°)	265	18	20	18	225	48	172 184	4.5	10	12	202	3	8	M16	(5/8")	18	5.22	5.15
200	216 (219.1°)	320	20	22	20	280	55	230 236	5.9	10	15	258	3	8	M16	(5/8")	18	7.15	7.78
250	267 (273°)	375	22	24	22	335	60	282 290	6.2	12	15	312	3	12	M16	(3/4")	18	9.61	10.8
300	318	440	22	24	22	395	62	335 342	7.1	12	15	365	4	12	M20	(3/4")	23	12.6	14.0
350	355.6° 368	490	22	26	22	445	62	385	7.1	12	15	415	4	12	M20	(3/4")	23	15.6	16.1
400	406.4° 419	540	22	28	22	495	65	438	7.1	12	15	455	4	16	M20	(3/4")	23	18.4	18.3
500	508° 521	645	24	30	24	600	68	538	7.1	12	15	570	4	20	M20	(7/8")	23	24.5	24.6
600	609.6° 622	755	24	-	-	705	70	640	7.1	12	16	670	5	20	M24	(7/8")	27	-	-
700	711.2° 720	860	24	-	-	810	70	740	7.1	12	16	775	5	24	M24	(1")	27	-	-
800	812.8° 820	975	24	-	-	920	70	842	7.1	12	16	880	5	24	M27	(1")	30	-	-
900	914.4° 920	1075	26	-	-	1020	70	942	7.1	12	16	980	5	24	M27	(1")	30	-	-
1000	1016° 1020	1175	26	-	-	1120	70	1045	7.1	16	16	1080	5	28	M27	(1")	30	-	-

Notes : Out side diameter of pipe complies with ISO recommendation R64

## DIN 2576 SLIP - ON FLANGES DIN 2527 BLIND FLANGES DIN 2632 WELDING NECK FLANGES

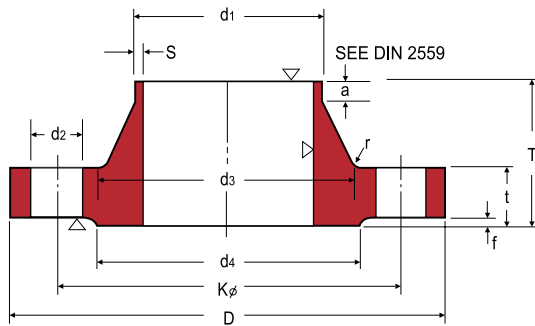

WELDING NECK

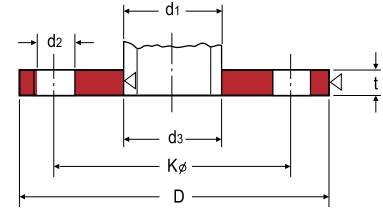

SLIP-ON/PLATE

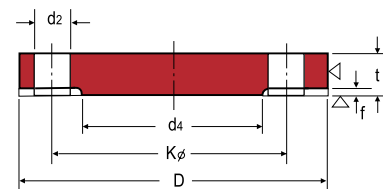

BLIND

Unit:mm

Nominal Bore	Bore		Common Dimension				Hub				Raised Face		Drilling			Approx.Weight(kg)			
	d <sub>1</sub>	D	t			K	T	d <sub>3</sub>	s	r	a	d <sub>4</sub>	f	Number of Bolt	Dia. of Bolt	d <sub>2</sub>	DIN 2632	DIN 2576	
			Welding Neck	Slip-on	Blind					≈									
10	14 17.2°)	90	14	14	14	60	35	25 28	1.8	4	6	40	2	4	M12	(1/2")	14	0.163	0.580
15	20 21.3°)	95	14	14	14	65	35	30 32	2.0	4	6	45	2	4	M12	(1/2")	14	0.675	0.648
20	25 26.9°)	105	16	16	16	75	38	38 40	2.3	4	6	58	2	4	M12	(1/2")	14	0.947	0.952
25	30 33.7°)	115	16	16	16	85	38	42 45	2.6	4	6	68	2	4	M12	(1/2")	14	1.14	1.14
32	38 42.4°)	140	16	16	16	100	40	52 56	2.6	6	6	78	2	4	M16	(5/8")	18	1.66	1.69
40	44.5 48.3°)	150	16	16	16	110	42	60 64	2.6	6	7	88	3	4	M16	(5/8")	18	1.89	1.86
50	57 60.3°)	165	18	18	18	125	45	72 75	2.9	6	8	102	3	4	M16	(5/8")	18	2.51	2.53
65	76.1°)	185	18	18	18	145	45	90	2.9	6	10	122	3	4	M16	(5/8")	18	3.00	3.06
80	88.9°)	200	20	20	20	160	50	105	3.2	8	10	138	3	4	M16	(5/8")	18	3.79	3.70
100	108 114.3°)	220	20	20	20	180	52	125 131	3.6	8	12	158	3	8	M16	(5/8")	18	4.20	4.62
125	133 139.7°)	250	22	22	22	210	55	150 156	4.0	8	12	188	3	8	M16	(5/8")	18	5.71	6.30
150	159 168.3°)	285	22	22	22	240	55	175 184	4.5	10	12	212	3	8	M20	(3/4")	23	6.72	7.75
200	216 219.1°)	340	24	24	24	295	62	232 235	5.9	10	16	268	3	8	M20	(3/4")	23	9.50	11.3
250	267 273°)	395	26	26	26	350	68	285 292	6.3	12	16	320	3	12	M20	(3/4")	23	12.5	14.7
300	318	445	26	26	28	400	68	335 344	7.1	12	16	370	4	12	M20	(3/4")	23	14.4	17.6
350	355.6°)	505	26	28	30	460	68	385	7.1	12	16	430	4	16	M20	(3/4")	23	20.6	21.4
400	406.4°)	565	26	32	32	515	72	440	7.1	12	16	482	4	16	M24	(7/8")	27	27.9	26.1
500	508°)	670	28	38	34	620	75	542	7.1	12	16	585	4	20	M24	(7/8")	27	41.1	34.7
600	609.6°)	780	28	-	-	725	80	642	7.1	12	18	685	5	20	M27	(1")	30	-	-
700	711.2°)	895	30	-	-	840	80	745	8.0	12	18	800	5	24	M27	(1")	30	-	-
800	812.8°)	1015	32	-	-	950	90	850	8.0	12	18	905	5	24	M30	(1 1/8")	33	-	-
900	914.4°)	1115	34	-	-	1050	95	950	10.0	12	20	1005	5	28	M30	(1 1/8")	33	-	-
1000	920 1016°)	1230	34	-	-	1160	95	1052	10.0	16	20	1110	5	28	M33	(1 1/8")	36	-	-

Notes : Out side diameter of pipe complies with ISO recommendation R64



# FITTINGS

- ASME B 16.9 Elbow
- ASME B 16.9 Elbow Tee/Cross/Return
- ASME B 16.9 Elbow Lap Joint
- ASME B 16.9 Elbow Caps
- ASME B 16.9 Elbow Reducers



# FITTINGS



**Reducer Fittings**



**Equal Tee - 250x250**



**Carbon Fittings**



**Steel Fittings**



**Equal Tee**



**Degree Elbows**

# BUTTWELD FITTINGS

A pipe fitting is defined as a part used in a piping system, to change direction or function, which is mechanically joined to the system.

Probably the simplest way to achieve this would be to bend the pipe in the direction required, but this process will stretch and thin the outer wall whilst thickening and wrinkling the inner wall. This results in flow resistance and accelerated wall erosion.

A second method sometimes used is a mitre joint, where pipes are cut to the correct angle and welded together to achieve the desired change. Whilst the cross-sectional area and wall thickness are maintained, a great deal of efficiency is lost due to friction and turbulence resulting from the severe changes in direction. For example, a single-mitre bend offers about six times the resistance of a swept elbow.

For these reasons swept fittings are preferred on most piping systems, particularly where internal pressure, flow and corrosion are of major consideration.

## TYPES AND APPLICATIONS OF BUTTWELD FITTINGS

A piping system using butt weld fittings has many inherent advantages over other forms.

- Welding a fitting to the pipe means it is permanently leakproof.
- The continuous metal structure formed between pipe and fitting adds strength to the system.
- Smooth inner surface and gradual directional changes reduce pressure losses and turbulence and minimise the action of corrosion and erosion.
- A welded system utilises a minimum of space.

## 90° ELBOWS

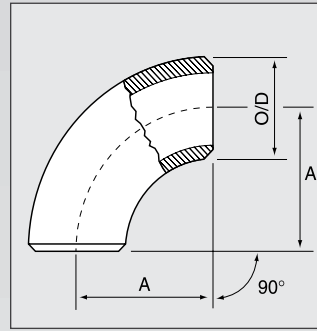

The function of a 90° elbow is to change direction or flow in a piping system.

Elbows are split into three groups which define the distance over which they change direction, expressed as a function of the distance from the centre line of one end to the opposite face.

This is known as the centre to face distance and is equivalent to the radius through which the elbow is bent.

### Long Radius Elbow

The most common is the long radius (L.R.) elbow where the centre to face dimension is always  $\frac{1}{2}$  times the nominal pipe size of the elbow.

### Short Radius Elbow

In this case the centre to face dimension is the same as the nominal pipe size of the elbow.

### Extra Long Radius

This is where the centre to face dimension is longer than the standard long radius type. The most common of these is where the centre to face dimension is three times the nominal size. i.e. 3D.

## 45° ELBOWS

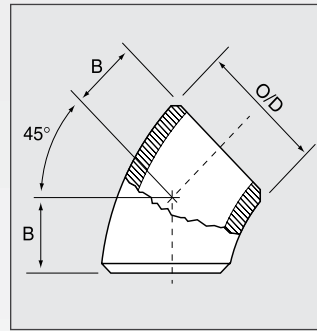

The function of a 45° elbow is the same as a 90° elbow, but the measurement of dimensions, however, is different to that of the 90° elbow. The radius of a 45° elbow is the same as the radius of the 90° L.R. elbow where 'R' equals  $1\frac{1}{2}$  D.

However, the centre to face dimension is not equivalent to the radius as in 90° L.R. elbows. This is measured from each face to the point of intersection of the centre lines perpendicular to each other. This is due to the smaller degree of bend.

## 180° RETURN BENDS

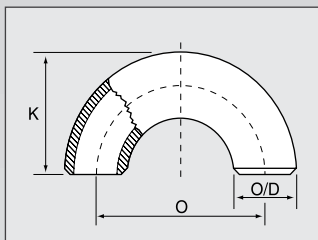

The function of a 180° return bend is to change direction of flow through 180° and there are two basic types, long radius and short radius. Both types have a centre to centre dimension double the matching 90° elbows. The

primary application for these fittings is in heater coils and heat exchangers, boilers etc.

## ECCENTRIC AND CONCENTRIC REDUCERS

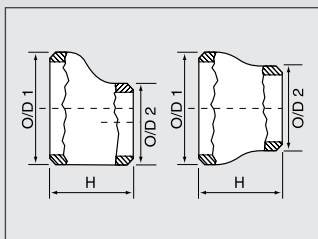

The function of both types of reducer is to reduce the line from a larger to a smaller pipe size, this obviously results in an increased flow pressure. With the eccentric reducer the smaller outlet end is off centre to the larger end enabling it to

line up with one side of the inlet and not with the other.

The concentric reducer is so manufactured that both inlet and outlet ends are on a common centre line. The concentric reducer is easier and less expensive to produce but does not allow quite the same versatility as the eccentric reducer. The lengths of both types are fixed by manufacturing standards.

## EQUAL AND REDUCING TEES

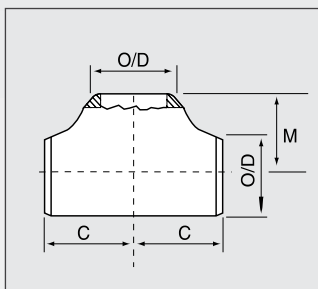

The function of a tee is to permit flow at 90° to the main direction of flow. The main flow passes through the 'run' whilst the 90° outlet is known as the 'branch'. The equal tee is manufactured with all three outlets being the same size.

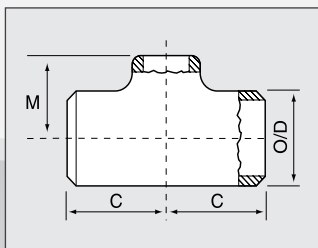

The reducing tee is manufactured with the branch outlet smaller than the run to obtain the desired flow and pressure through the system.

## EQUAL AND REDUCING CROSSES

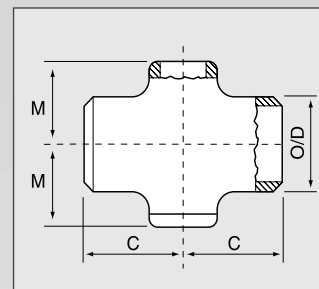
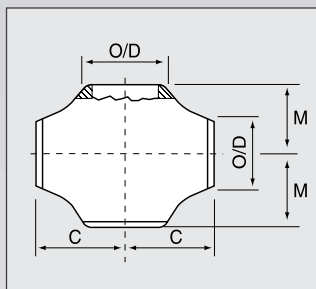

The function of a cross is similar to that of a tee with the exception of providing two 90° outlets opposite each other. Equal crosses have all four outlets of equal size. Reducing crosses have branches that are smaller in size to that of the run to obtain the desired flow and pressure through the system.

## CAPS

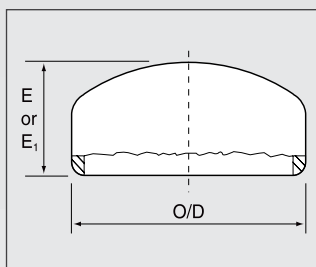

The function of an end cap is to block off the end of a line in piping systems. This is achieved by placing the end cap over the open line and welding around the joint.

## LAP JOINT STUB ENDS

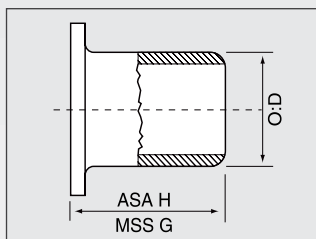

A lap joint stub end and its associated slip-on flange in a piping system allows quick disconnection of the particular section involved. Stub ends are installed in pairs and mated together with two lap joint flanges.

The surface of the stub end has a phonographic serrated gasket surface which prevents leakage at the joint. Using stub ends allows sections of the line to be opened for cleaning, inspection or quick replacement etc., without the need to re-weld.

There are two basic types of stub end, ANSI types A & B long barrel, and M.S.S. types short barrel. Under certain design criteria such as temperature or pressure, etc., it is not acceptable to have the joint between stub end and pipe in close proximity with the flange joint, in these applications ANSI types are used.

## BUTT WELDED FITTINGS (ASME B 16.9)

\*All dimensions are in inches.

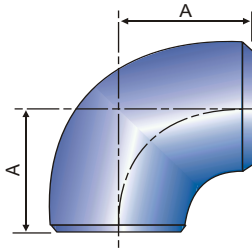

**Straight type  
Long Radius  
Elbow (90°)**

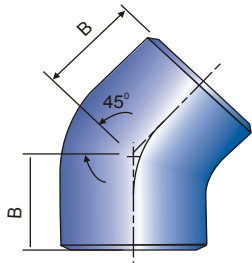

**Straight type  
Long Radius  
Elbow (45°)**

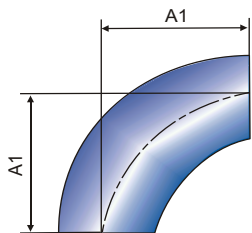

**Reducing type  
Long Radius  
Elbow (90°)**

NOMINAL PIPE SIZE (NPS)	OUTSIDE DIAMETER AT BEVEL D.	CENTER-TO-END	
		90 DEG. ELBOWS	45 DEG. ELBOWS
		A.	B.
1/2	0.84	1.50	0.62
3/4	1.05	1.50	0.75
1	1.32	1.50	0.88
1 1/4	1.66	1.88	1.00
1 1/2	1.90	2.25	1.12
2	2.38	3.00	1.38
2 1/2	2.88	3.75	1.75
3	3.50	4.50	2.00
3 1/2	4.00	5.25	2.25
4	4.50	6.00	2.50
5	5.56	7.50	3.12
6	6.62	9.00	3.75
8	8.62	12.00	5.00
10	10.75	15.00	6.25
12	12.75	18.00	7.50
14	14.00	21.00	8.75

NOMINAL PIPE SIZE (NPS)	OUTSIDE DIAMETER AT BEVEL D.	CENTER-TO-END	
		90 DEG. ELBOWS	45 DEG. ELBOWS
		A.	B.
16	16.00	24.00	10.00
18	18.00	27.00	11.25
20	20.00	30.00	12.50
22	22.00	33.00	13.50
24	24.00	36.00	15.00
26	26.00	39.00	16.00
28	28.00	42.00	17.25
30	30.00	45.00	18.50
32	32.00	48.00	19.75
34	34.00	51.00	21.00
36	36.00	54.00	22.25
38	38.00	57.00	23.62
40	40.00	60.00	24.88
42	42.00	63.00	26.00
44	44.00	66.00	27.38
46	46.00	69.00	28.62
48	48.00	72.00	29.88

NOMINAL PIPE SIZE (NPS)	OUTSIDE DIAMETER AT BEVEL D		CENTER- TO- END A1.
	LARGE END	SMALL END	
	2 x 1 1/2	2.38	
2 x 1 1/4	2.38	1.66	3.00
2 x 1	2.38	1.32	3.00
2 1/2 x 2	2.88	2.38	3.75
2 1/2 x 1 1/2	2.88	1.90	3.75
2 1/2 x 1 1/4	2.88	1.66	3.75
3 x 2 1/2	3.50	2.88	4.50
3 x 2	3.50	2.38	4.50
3 x 1 1/2	3.50	1.90	4.50
3 1/2 x 3	4.00	3.50	5.25
3 1/2 x 2 1/2	4.00	2.88	5.25
3 1/2 x 2	4.00	2.38	5.25
4 x 3 1/2	4.50	4.00	6.00
4 x 3	4.50	3.50	6.00
4 x 2 1/2	4.50	2.88	6.00
4 x 2	4.50	2.38	6.00
5 x 4	5.56	4.50	7.50
5 x 3 1/2	5.56	4.00	7.50
5 x 3	5.56	3.50	7.50
5 x 2 1/2	5.56	2.88	7.50
6 x 5	6.62	5.56	9.00
6 x 4	6.62	4.50	9.00
6 x 3 1/2	6.62	4.00	9.00
6 x 3	6.62	3.50	9.00
8 x 6	8.62	6.62	12.00
8 x 5	8.62	5.56	12.00
8 x 4	8.62	4.50	12.00

NOMINAL PIPE SIZE (NPS)	OUTSIDE DIAMETER AT BEVEL D.		CENTER- TO- END A1.
	LARGE END	SMALL END	
	10 x 8	10.75	
10 x 6	10.75	6.62	15.00
10 x 5	10.75	5.56	15.00
12 x 10	12.75	10.75	18.00
12 x 8	12.75	8.62	18.00
12 x 6	12.75	6.62	18.00
14 x 12	14.00	12.75	21.00
14 x 10	14.00	10.75	21.00
14 x 8	14.00	8.62	21.00
16 x 14	16.00	14.00	24.00
16 x 12	16.00	12.75	24.00
16 x 10	16.00	10.75	24.00
18 x 16	18.00	16.00	27.00
18 x 14	18.00	14.00	27.00
18 x 12	18.00	12.75	27.00
18 x 10	18.00	10.75	27.00
20 x 18	20.00	18.00	30.00
20 x 16	20.00	16.00	30.00
20 x 14	20.00	14.00	30.00
20 x 12	20.00	12.75	30.00
20 x 10	20.00	10.75	30.00
24 x 22	24.00	22.00	36.00
24 x 20	24.00	20.00	36.00
24 x 18	24.00	18.00	36.00
24 x 16	24.00	16.00	36.00
24 x 14	24.00	14.00	36.00
24 x 12	24.00	12.75	36.00

## BUTT WELDED FITTINGS (ASME B 16.9)

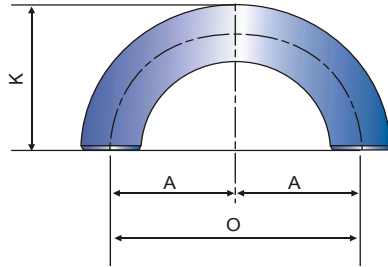

**Long Radius Returns**

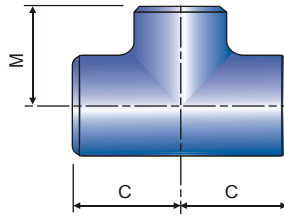

**Straight Tees**

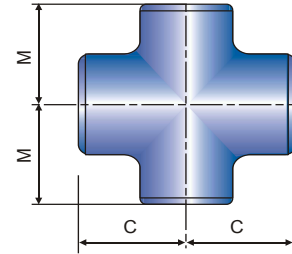

**Straight Crosses**

\*All dimensions are in inches.

NOMINAL PIPE SIZE (NPS)	OUTSIDE DIAMETER AT BEVEL D.	CENTRE -TO- CENTRE O.	BACK -TO- FACE K.
1/2	0.840	3.00	1.875
3/4	1.050	2.25	1.6875
1	1.315	3.00	2.1875
1 1/4	1.660	3.75	2.75
1 1/2	1.900	4.50	3.25
2	2.375	6.00	4.1875
2 1/2	2.875	7.50	5.1875
3	3.500	9.00	6.25
3 1/2	4.000	10.50	7.25
4	4.500	12.00	8.25
5	5.563	15.00	10.3125
6	6.625	18.00	12.3125
8	8.625	24.00	16.3125
10	10.750	30.00	20.375
12	12.750	36.00	24.38
14	14.000	42.00	28.00
16	16.000	48.00	32.00
18	18.000	54.00	36.00
20	20.000	60.00	40.00
22	22.000	66.00	44.00
24	24.000	72.00	48.00

NOMINAL PIPE SIZE (NPS)	OUTSIDE DIAMETER AT BEVEL D.	CENTER-TO-END	
		RUN C.	OUTLET M.
1/2	0.840	1.00	1.00
3/4	1.050	1.125	1.125
1	1.315	1.50	1.50
1 1/4	1.660	1.875	1.875
1 1/2	1.900	2.25	2.25
2	2.375	2.50	2.50
2 1/2	2.875	3.00	3.00
3	3.50	3.375	3.375
3 1/2	4.00	3.75	3.75
4	4.50	4.125	4.125
5	5.563	4.875	4.875
6	6.625	5.625	5.625
8	8.625	7.00	7.00
10	10.750	8.500	8.50
12	12.750	10.00	10.00
14	14.000	11.00	11.00
16	16.000	12.00	12.00
18	18.000	13.50	13.50
20	20.000	15.00	15.00
22	22.000	16.50	16.50
24	24.000	17.00	17.00
26	26.000	19.50	19.50
28	28.000	20.50	20.50
30	30.000	22.00	22.00
32	32.000	23.50	23.50
34	34.000	25.00	25.00
36	36.000	26.50	26.50
38	38.000	28.00	28.00
40	40.000	29.50	29.50
42	42.000	30.00	28.00
44	44.000	32.00	30.00
46	46.000	33.50	31.50
48	48.000	35.00	33.00



## BUTT WELDED FITTINGS (ASME B 16.9)

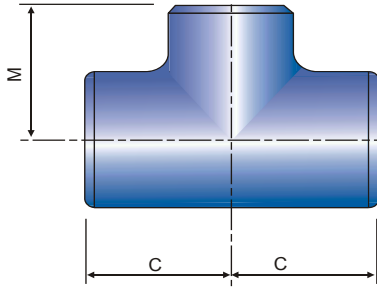

**Reducing Outlet Tees**

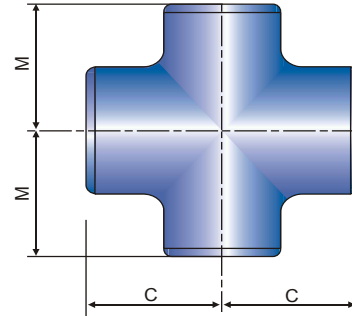

**Reducing Outlet Crosses**

### Reducing Tees & Crosses

\*All dimensions are in inches.

NOMINAL PIPE SIZE (NPS)	OUTSIDE DIAMETER AT BEVEL D.		CENTER-TO-END	
	RUN	OUTLET	RUN	OUTLET
			C.	M.
1/2 x 1/2 x 1/4	0.840	0.68	1.00	1.00
1/2 x 1/2 x 3/8	0.840	0.54	1.00	1.00
3/4 x 3/4 x 3/8	1.050	0.84	1.12	1.12
3/4 x 3/4 x 1/2	1.010	0.68	1.12	1.12
1 x 1 x 3/4	1.315	1.05	1.50	1.50
1 x 1 x 1/2	1.315	0.84	1.50	1.50
1 1/4 x 1 1/4 x 1	1.66	1.32	1.88	1.88
1 1/4 x 1 1/4 x 3/4	1.66	1.05	1.88	1.88
1 1/4 x 1 1/4 x 1/2	1.66	0.84	1.88	1.88
1 1/2 x 1 1/2 x 1 1/4	1.90	1.66	2.25	2.25
1 1/2 x 1 1/2 x 1	1.90	1.32	2.25	2.25
1 1/2 x 1 1/2 x 3/4	1.90	1.05	2.25	2.25
1 1/2 x 1 1/2 x 1/2	1.90	0.84	2.25	2.25
2 x 2 x 1 1/2	2.375	1.90	2.50	2.38
2 x 2 x 1 1/4	2.375	1.66	2.50	2.25
2 x 2 x 1	2.375	1.32	2.50	2.00
2 x 2 x 3/4	2.375	1.05	2.50	1.75
2 1/2 x 2 1/2 x 2	2.875	2.38	3.00	2.75
2 1/2 x 2 1/2 x 1 1/2	2.875	1.90	3.00	2.62
2 1/2 x 2 1/2 x 1 1/4	2.875	1.66	3.00	2.50
2 1/2 x 2 1/2 x 1	2.875	1.32	3.00	2.25
3 x 3 x 2 1/2	3.50	2.88	3.38	3.25
3 x 3 x 2	3.50	2.38	3.38	3.00
3 x 3 x 1 1/2	3.50	1.90	3.38	2.88
3 x 3 x 1 1/4	3.50	1.66	3.38	2.75
3 1/2 x 3 1/2 x 3	4.00	3.50	3.75	3.62
3 1/2 x 3 1/2 x 2 1/2	4.00	2.88	3.75	3.50
3 1/2 x 3 1/2 x 2	4.00	2.38	3.75	3.25
3 1/2 x 3 1/2 x 1 1/2	4.00	1.90	3.75	3.12
4 x 4 x 3 1/2	4.50	4.00	4.12	4.00
4 x 4 x 3	4.50	3.50	4.12	3.88
4 x 4 x 2 1/2	4.50	2.88	4.12	3.75
4 x 4 x 2	4.50	2.38	4.12	3.50
4 x 4 x 1 1/2	4.50	1.90	4.12	3.38
5 x 5 x 4	5.563	4.50	4.88	4.62
5 x 5 x 3 1/2	5.563	4.00	4.88	4.50
5 x 5 x 3	5.563	3.50	4.88	4.38
5 x 5 x 2 1/2	5.563	2.88	4.88	4.25
5 x 5 x 2	5.563	2.38	4.88	4.12

NOMINAL PIPE SIZE (NPS)	OUTSIDE DIAMETER AT BEVEL D.		CENTER-TO-END	
	RUN	OUTLET	RUN	OUTLET
			C.	M.
6 x 6 x 5	6.625	5.56	5.62	5.38
6 x 6 x 4	6.625	4.50	5.62	5.12
6 x 6 x 3 1/2	6.625	4.00	5.62	5.00
6 x 6 x 3	6.625	3.50	5.62	4.88
6 x 6 x 2 1/2	6.625	2.88	5.62	4.75
8 x 8 x 6	8.625	6.62	7.00	6.62
8 x 8 x 5	8.625	5.56	7.00	6.38
8 x 8 x 4	8.625	4.50	7.00	6.12
8 x 8 x 3 1/2	8.625	4.00	7.00	6.00
10 x 10 x 8	10.75	8.62	8.50	8.00
10 x 10 x 6	10.75	6.62	8.50	7.62
10 x 10 x 5	10.75	5.56	8.50	7.50
10 x 10 x 4	10.75	4.50	8.50	7.25
12 x 12 x 10	12.75	10.75	10.00	9.50
12 x 12 x 8	12.75	8.62	10.00	9.00
12 x 12 x 6	12.75	6.62	10.00	8.62
12 x 12 x 5	12.75	5.56	10.00	8.50
14 x 14 x 12	14.00	12.75	11.00	10.62
14 x 14 x 10	14.00	10.75	11.00	10.12
14 x 14 x 8	14.00	8.62	11.00	9.75
14 x 14 x 6	14.00	6.62	11.00	9.38
16 x 16 x 14	16.00	14.00	12.00	12.00
16 x 16 x 12	16.00	12.75	12.00	11.62
16 x 16 x 10	16.00	10.75	12.00	11.12
16 x 16 x 8	16.00	8.62	12.00	10.75
16 x 16 x 6	16.00	6.62	12.00	10.38
18 x 18 x 16	18.00	16.00	13.50	13.00
18 x 18 x 14	18.00	14.00	13.50	13.00
18 x 18 x 12	18.00	12.75	13.50	12.62
18 x 18 x 10	18.00	10.75	13.50	12.12
18 x 18 x 8	18.00	8.62	13.50	11.75
20 x 20 x 18	20.00	18.00	15.00	14.50
20 x 20 x 16	20.00	16.00	15.00	14.00
20 x 20 x 14	20.00	14.00	15.00	14.00
20 x 20 x 12	20.00	12.75	15.00	13.62
20 x 20 x 10	20.00	10.75	15.00	13.12
20 x 20 x 8	20.00	8.62	15.00	12.75
22 x 22 x 20	22.00	20.00	16.50	16.00
22 x 22 x 18	22.00	18.00	16.50	15.50



## BUTT WELDED FITTINGS (ASME B 16.9)

\*All dimensions are in inches.

NOMINAL PIPE SIZE (NPS)	OUTSIDE DIAMETER AT BEVEL D.		CENTER-TO-END	
	RUN	OUTLET	RUN	OUTLET
			C.	M.
22 x 22 x 16	22.00	16.00	16.50	15.00
22 x 22 x 14	22.00	14.00	16.50	15.00
22 x 22 x 12	22.00	12.75	16.50	14.625
22 x 22 x 10	22.00	10.75	16.50	14.125
24 x 24 x 22	24.00	22.00	17.00	17.00
24 x 24 x 20	24.00	20.00	17.00	17.00
24 x 24 x 18	24.00	18.00	17.00	16.50
24 x 24 x 16	24.00	16.00	17.00	16.00
24 x 24 x 14	24.00	14.00	17.00	16.00
24 x 24 x 12	24.00	12.75	17.00	15.625
24 x 24 x 10	24.00	10.75	17.00	15.125
26 x 26 x 24	26.00	24.00	19.50	19.00
26 x 26 x 22	26.00	22.00	19.50	18.50
26 x 26 x 20	26.00	20.00	19.50	18.00
26 x 26 x 18	26.00	18.00	19.50	17.50
26 x 26 x 16	26.00	16.00	19.50	17.00
26 x 26 x 14	26.00	14.00	19.50	17.00
26 x 26 x 12	26.00	12.75	19.50	16.625
28 x 28 x 26	28.00	26.00	20.50	20.50
28 x 28 x 24	28.00	24.00	20.50	20.00
28 x 28 x 22	28.00	22.00	20.50	19.50
28 x 28 x 20	28.00	20.00	20.50	19.00
28 x 28 x 18	28.00	18.00	20.50	18.50
28 x 28 x 16	28.00	16.00	20.50	18.00
28 x 28 x 14	28.00	14.00	20.50	18.00
28 x 28 x 12	28.00	12.75	20.50	17.625
30 x 30 x 28	30.00	28.00	22.00	21.50
30 x 30 x 26	30.00	26.00	22.00	21.50
30 x 30 x 24	30.00	24.00	22.00	21.00
30 x 30 x 22	30.00	22.00	22.00	20.50
30 x 30 x 20	30.00	20.00	22.00	20.00
30 x 30 x 18	30.00	18.00	22.00	19.50
30 x 30 x 16	30.00	16.00	22.00	19.00
30 x 30 x 14	30.00	14.00	22.00	19.00
30 x 30 x 12	30.00	12.75	22.00	18.625
30 x 30 x 10	30.00	10.75	22.00	18.125
32 x 32 x 30	32.00	30.00	23.50	23.00
32 x 32 x 28	32.00	28.00	23.50	22.50
32 x 32 x 26	32.00	26.00	23.50	22.50
32 x 32 x 24	32.00	24.00	23.50	22.00
32 x 32 x 22	32.00	22.00	23.50	21.50
32 x 32 x 20	32.00	20.00	23.50	21.00
32 x 32 x 18	32.00	18.00	23.50	20.50
32 x 32 x 16	32.00	16.00	23.50	20.00
32 x 32 x 14	32.00	14.00	23.50	20.00
34 x 34 x 32	34.00	32.00	25.00	24.50
34 x 34 x 30	34.00	30.00	25.00	24.00
34 x 34 x 28	34.00	28.00	25.00	23.50
34 x 34 x 26	34.00	26.00	25.00	23.50

NOMINAL PIPE SIZE (NPS)	OUTSIDE DIAMETER AT BEVEL D.		CENTER-TO-END	
	RUN	OUTLET	RUN	OUTLET
			C.	M.
34 x 34 x 24	34.00	24.00	25.00	23.00
34 x 34 x 22	34.00	22.00	25.00	22.50
34 x 34 x 20	34.00	20.00	25.00	22.00
34 x 34 x 18	34.00	18.00	25.00	21.50
34 x 34 x 16	34.00	16.00	25.00	21.00
36 x 36 x 34	36.00	34.00	26.50	26.00
36 x 36 x 32	36.00	32.00	26.50	25.50
36 x 36 x 30	36.00	30.00	26.50	25.00
36 x 36 x 28	36.00	28.00	26.50	24.50
36 x 36 x 26	36.00	26.00	26.50	24.50
36 x 36 x 24	36.00	24.00	26.50	24.00
36 x 36 x 22	36.00	22.00	26.50	23.50
36 x 36 x 20	36.00	20.00	26.50	23.00
36 x 36 x 18	36.00	18.00	26.50	22.50
36 x 36 x 16	36.00	16.00	26.50	22.00
38 x 38 x 36	38.00	36.00	28.00	28.00
38 x 38 x 34	38.00	34.00	28.00	27.50
38 x 38 x 32	38.00	32.00	28.00	27.00
38 x 38 x 30	38.00	30.00	28.00	26.50
38 x 38 x 28	38.00	28.00	28.00	25.50
38 x 38 x 26	38.00	26.00	28.00	25.50
38 x 38 x 24	38.00	24.00	28.00	25.00
38 x 38 x 22	38.00	22.00	28.00	24.50
38 x 38 x 20	38.00	20.00	28.00	24.00
38 x 38 x 18	38.00	18.00	28.00	23.50
40 x 40 x 38	40.00	38.00	29.50	29.50
40 x 40 x 36	40.00	36.00	29.50	29.00
40 x 40 x 34	40.00	34.00	29.50	28.50
40 x 40 x 32	40.00	32.00	29.50	28.00
40 x 40 x 30	40.00	30.00	29.50	27.50
40 x 40 x 28	40.00	28.00	29.50	26.50
40 x 40 x 26	40.00	26.00	29.50	26.50
40 x 40 x 24	40.00	24.00	29.50	26.00
40 x 40 x 22	40.00	22.00	29.50	25.50
40 x 40 x 20	40.00	20.00	29.50	25.00
42 x 42 x 40	42.00	40.00	30.00	28.00
42 x 42 x 38	42.00	38.00	30.00	28.00
42 x 42 x 36	42.00	36.00	30.00	28.00
42 x 42 x 34	42.00	34.00	30.00	28.00
42 x 42 x 32	42.00	32.00	30.00	28.00
42 x 42 x 30	42.00	30.00	30.00	28.00
42 x 42 x 28	42.00	28.00	30.00	27.50
42 x 42 x 26	42.00	26.00	30.00	27.50
42 x 42 x 24	42.00	24.00	30.00	26.00
42 x 42 x 22	42.00	22.00	30.00	26.00
42 x 42 x 20	42.00	20.00	30.00	26.00
42 x 42 x 18	42.00	18.00	30.00	25.50
42 x 42 x 16	42.00	16.00	30.00	25.00

## BUTT WELDED FITTINGS

### 1 BUTT WELDED FITTINGS (ASME B 16.9)

\*All dimensions are in inches.

NOMINAL PIPE SIZE (NPS)	OUTSIDE DIAMETER AT BEVEL D.		CENTER - TO - END	
	RUN	OUTLET	RUN C.	OUTLET M.
44 x 44 x 42	44.00	42.00	32.00	30.00
44 x 44 x 40	44.00	40.00	32.00	29.50
44 x 44 x 38	44.00	38.00	32.00	29.00
44 x 44 x 36	44.00	36.00	32.00	28.50
44 x 44 x 34	44.00	34.00	32.00	28.50
44 x 44 x 32	44.00	32.00	32.00	28.00
44 x 44 x 30	44.00	30.00	32.00	28.00
44 x 44 x 28	44.00	28.00	32.00	27.50
44 x 44 x 26	44.00	26.00	32.00	27.50
44 x 44 x 24	44.00	24.00	32.00	27.50
44 x 44 x 22	44.00	22.00	32.00	27.00
44 x 44 x 20	44.00	20.00	32.00	27.00
46 x 46 x 44	46.00	44.00	33.50	31.50
46 x 46 x 42	46.00	42.00	33.50	31.00
46 x 46 x 40	46.00	40.00	33.50	30.50
46 x 46 x 38	46.00	38.00	33.50	30.00
46 x 46 x 36	46.00	36.00	33.50	30.00
46 x 46 x 34	46.00	34.00	33.50	29.50
46 x 46 x 32	46.00	32.00	33.50	29.50
46 x 46 x 30	46.00	30.00	33.50	29.00
46 x 46 x 28	46.00	28.00	33.50	29.00
46 x 46 x 26	46.00	26.00	33.50	29.00
46 x 46 x 24	46.00	24.00	33.50	28.50
46 x 46 x 22	46.00	22.00	33.50	28.50
48 x 48 x 46	48.00	46.00	35.00	33.00
48 x 48 x 44	48.00	44.00	35.00	33.00
48 x 48 x 42	48.00	42.00	35.00	32.00
48 x 48 x 40	48.00	40.00	35.00	32.00
48 x 48 x 38	48.00	38.00	35.00	32.00
48 x 48x 36	48.00	36.00	35.00	31.00
48 x 48 x 34	48.00	34.00	35.00	31.00
48 x 48 x 32	48.00	32.00	35.00	31.00
48 x 48 x 30	48.00	30.00	35.00	30.00
48 x 48 x 28	48.00	28.00	35.00	30.00
48 x 48 x 26	48.00	26.00	35.00	30.00
48 x 48 x 24	48.00	24.00	35.00	29.00
48 x 48 x 22	48.00	22.00	35.00	29.00

## BUTT WELDED FITTINGS

### 1 BUTT WELDED FITTINGS (ASME B 16.9)

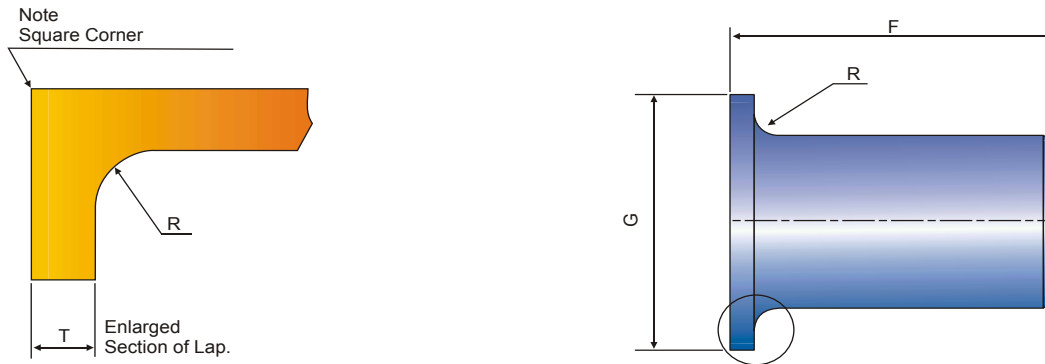

*Lap Joint Stub Ends*

\*All dimensions are in inches.

NOMINAL PIPE SIZE (NPS)	OUTSIDE DIAMETER AT BEVEL - D.	LONG PATTERN LENGTH - F.	SHORT PATTERN LENGTH - F.	RADIUS OF FILLET-R.	DIAMETER OF LAP-G.	OUTSIDE DIAMETER OF BARREL	
						MAX.	MIN.
1/2	0.840	3.00	2.00	0.125	1.375	0.896	0.809
3/4	1.050	3.00	2.00	0.125	1.6875	1.106	1.019
1	1.315	4.00	2.00	0.125	2.00	1.376	1.284
1 1/4	1.660	4.00	2.00	0.1875	2.50	1.716	1.629
1 1/2	1.900	4.00	2.00	0.25	2.875	1.966	1.869
2	2.375	6.00	2.50	0.3125	3.625	2.456	2.344
2 1/2	2.875	6.00	2.50	0.3125	4.125	2.966	2.844
3	3.50	6.00	2.50	0.375	5.00	3.596	3.469
3 1/2	4.00	6.00	3.00	0.375	5.50	4.096	3.969
4	4.50	6.00	3.00	0.4375	6.1875	4.593	4.469
5	5.563	8.00	3.00	0.4375	7.3125	5.683	5.532
6	6.625	8.00	3.50	0.50	8.50	6.743	6.594
8	8.625	8.00	4.00	0.50	10.625	8.743	8.594
10	10.75	10.00	5.00	0.50	12.75	10.913	10.719
12	12.75	10.00	6.00	0.50	15.00	12.913	12.719
14	14.00	12.00	6.00	0.50	16.25	14.170	13.969
16	16.00	12.00	6.00	0.50	18.50	16.180	15.969
18	18.00	12.00	6.00	0.50	21.00	18.190	17.969
20	20.00	12.00	6.00	0.50	23.00	20.240	19.969
22	22.00	12.00	6.00	0.50	25.25	22.240	21.969
24	24.00	12.00	6.00	0.50	27.25	24.240	23.969

## BUTT WELDED FITTINGS

### 1 BUTT WELDED FITTINGS (ASME B 16.9)

\*All dimensions are in inches.

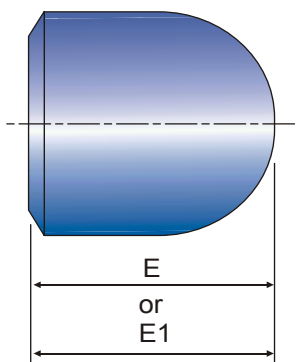

**Caps**

NOMINAL PIPE SIZE (NPS)	OUTSIDE DIAMETER AT BEVEL D.	LENGTH E.	LIMITING WALL THICKNESS FOR LENGTH E.	LENGTH E1.
1/2	0.84	1.00	0.147	1.00
3/4	1.05	1.00	0.154	1.00
1	1.315	1.50	0.179	1.50
1 1/4	1.66	1.50	0.191	1.50
1 1/2	1.90	1.50	0.20	1.50
2	2.375	1.50	0.218	1.75
2 1/2	2.875	1.50	0.276	2.00
3	3.50	2.00	0.30	2.50
3 1/2	4.00	2.50	0.318	3.00
4	4.50	2.50	0.337	3.00
5	5.563	3.00	0.375	3.50
6	6.625	3.50	0.432	4.00
8	8.625	4.00	0.50	5.00
10	10.75	5.00	0.50	6.00
12	12.75	6.00	0.50	7.00
14	14.00	6.50	0.50	7.50
16	16.00	7.00	0.50	8.00
18	18.00	8.00	0.50	9.00
20	20.00	9.00	0.50	10.00
22	22.00	10.00	0.50	10.00
24	24.00	10.50	0.50	12.00
26	26.00	10.50	-	-
28	28.00	10.50	-	-
30	30.00	10.50	-	-
32	32.00	10.50	-	-
34	34.00	10.50	-	-
36	36.00	10.50	-	-
38	38.00	12.00	-	-
40	40.00	12.00	-	-
42	42.00	12.00	-	-
44	44.00	13.50	-	-
46	46.00	13.50	-	-
48	48.00	13.50	-	-

**General Notes:**

The shape of these Caps shall be ellipsoidal and shall conform to the shape requirements as given in the ASME Boiler & Pressure Vessel Code.

**Notes:**

- a. Length E applies for thickness not exceeding that given in column "Limiting Wall Thickness for Length E"
- b. Length E1 applies for thickness greater than that given in column "Limiting Wall Thickness" for NPS 24 and smaller. For NPS 26 and larger, length E1 shall be by agreement between manufacturer and purchaser.

## BUTT WELDED FITTINGS

### 1 BUTT WELDED FITTINGS (ASME B 16.9)

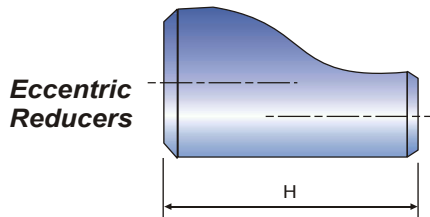
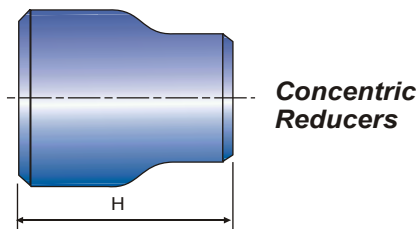

\*All dimensions are in inches.

NOMINAL PIPE SIZE (NPS)	OUTSIDE DIAMETER AT BEVEL D.		END-TO-END H.
	LARGE END	SMALL END	
3/4 x 3/8	1.05	0.675	1.50
3/4 x 1/2	1.05	0.840	1.50
1 x 3/4	1.32	1.05	2.00
1 x 1/2	1.32	0.84	2.00
1 1/4 x 1	1.66	1.315	2.00
1 1/4 x 3/4	1.66	1.05	2.00
1 1/4 x 1/2	1.66	0.840	2.00
1 1/2 x 1 1/4	1.90	1.660	2.50
1 1/2 x 1	1.90	1.315	2.50
1 1/2 x 3/4	1.90	1.05	2.50
1 1/2 x 1/2	1.90	0.84	2.50
2 x 1 1/2	2.38	1.90	3.00
2 x 1 1/4	2.38	1.66	3.00
2 x 1	2.38	1.315	3.00
2 x 3/4	2.38	1.050	3.00
2 1/2 x 2	2.88	2.375	3.50
2 1/2 x 1 1/2	2.88	1.900	3.50
2 1/2 x 1 1/4	2.88	1.660	3.50
2 1/2 x 1	2.88	1.315	3.50
3 x 2 1/2	3.50	2.875	3.50
3 x 2	3.50	2.375	3.50
3 x 1 1/2	3.50	1.90	3.50
3 x 1 1/4	3.50	1.660	3.50
3 1/2 x 3	4.00	3.50	4.00
3 1/2 x 2 1/2	4.00	2.875	4.00
3 1/2 x 2	4.00	2.375	4.00
3 1/2 x 1 1/2	4.00	1.90	4.00
3 1/2 x 1 1/4	4.00	1.66	4.00
4 x 3 1/2	4.50	4.00	4.00
4 x 3	4.50	3.50	4.00
4 x 2 1/2	4.50	2.875	4.00
4 x 2	4.50	2.375	4.00
4 x 1 1/2	4.50	1.90	4.00
5 x 4	5.56	4.50	5.00
5 x 3 1/2	5.56	4.00	5.00
5 x 3	5.56	3.50	5.00
5 x 2 1/2	5.56	2.875	5.00
5 x 2	5.56	2.375	5.00

NOMINAL PIPE SIZE (NPS)	OUTSIDE DIAMETER AT BEVEL D.		END-TO-END H.
	LARGE END	SMALL END	
6 x 5	6.625	5.563	5.50
6 x 4	6.625	4.50	5.50
6 x 3 1/2	6.625	4.00	5.50
6 x 3	6.625	3.50	5.50
6 x 2 1/2	6.625	2.875	5.50
8 x 6	8.625	6.625	6.00
8 x 5	8.625	5.563	6.00
8 x 4	8.625	4.50	6.00
8 x 3 1/2	8.625	4.00	6.00
10 x 8	10.75	8.625	7.00
10 x 6	10.75	6.625	7.00
10 x 5	10.75	5.563	7.00
10 x 4	10.75	4.50	7.00
12 x 10	12.75	10.75	8.00
12 x 8	12.75	8.625	8.00
12 x 6	12.75	6.625	8.00
12 x 5	12.75	5.563	8.00
14 x 12	14.00	12.75	13.00
14 x 10	14.00	10.75	13.00
14 x 8	14.00	8.625	13.00
14 x 6	14.00	6.625	13.00
16 x 14	16.00	14.00	14.00
16 x 12	16.00	12.75	14.00
16 x 10	16.00	10.75	14.00
16 x 8	16.00	8.625	14.00
18 x 16	18.00	16.00	15.00
18 x 14	18.00	14.00	15.00
18 x 12	18.00	12.75	15.00
18 x 10	18.00	10.75	15.00
20 x 18	20.00	18.00	20.00
20 x 16	20.00	16.00	20.00
20 x 14	20.00	14.00	20.00
20 x 12	20.00	12.75	20.00
22 x 20	22.00	20.00	20.00
22 x 18	22.00	18.00	20.00
22 x 16	22.00	16.00	20.00
22 x 14	22.00	14.00	20.00

## BUTT WELDED FITTINGS

### 1 BUTT WELDED FITTINGS (ASME B 16.9)

#### Concentric & Eccentric Reducers

\*All dimensions are in inches.

NOMINAL PIPE SIZE (NPS)	OUTSIDE DIAMETER AT BEVEL D.		END-TO -END H.
	LARGE END	SMALL END	
24 x 22	24.00	22.00	20.00
24 x 20	24.00	20.00	20.00
24 x 18	24.00	18.00	20.00
24 x 16	24.00	16.00	20.00
26 x 24	26.00	24.00	24.00
26 x 22	26.00	22.00	24.00
26 x 20	26.00	20.00	24.00
26 x 18	26.00	18.00	24.00
28 x 26	28.00	26.00	24.00
28 x 24	28.00	24.00	24.00
28 x 20	28.00	20.00	24.00
28 x 18	28.00	18.00	24.00
30 x 28	30.00	28.00	24.00
30 x 26	30.00	26.00	24.00
30 x 24	30.00	24.00	24.00
30 x 20	30.00	20.00	24.00
32 x 30	32.00	30.00	24.00
32 x 28	32.00	28.00	24.00
32 x 26	32.00	26.00	24.00
32 x 24	32.00	24.00	24.00
34 x 32	34.00	32.00	24.00
34 x 30	34.00	30.00	24.00
34 x 26	34.00	26.00	24.00
34 x 24	34.00	24.00	24.00
36 x 34	36.00	34.00	24.00
36 x 32	36.00	32.00	24.00
36 x 30	36.00	30.00	24.00
36 x 26	36.00	26.00	24.00
36 x 24	36.00	24.00	24.00

NOMINAL PIPE SIZE (NPS)	OUTSIDE DIAMETER AT BEVEL D.		END-TO -END H.
	LARGE END	SMALL END	
38 x 36	38.00	36.00	24.00
38 x 34	38.00	34.00	24.00
38 x 32	38.00	32.00	24.00
38 x 30	38.00	30.00	24.00
38 x 28	38.00	28.00	24.00
38 x 26	38.00	26.00	24.00
40 x 38	40.00	38.00	24.00
40 x 36	40.00	36.00	24.00
40 x 34	40.00	34.00	24.00
40 x 32	40.00	32.00	24.00
40 x 30	40.00	30.00	24.00
42 x 40	42.00	40.00	24.00
42 x 38	42.00	38.00	24.00
42 x 36	42.00	36.00	24.00
42 x 34	42.00	34.00	24.00
42 x 32	42.00	32.00	24.00
42 x 30	42.00	30.00	24.00
44 x 42	44.00	42.00	24.00
44 x 40	44.00	40.00	24.00
44 x 38	44.00	38.00	24.00
44 x 36	44.00	36.00	24.00
46 x 44	46.00	44.00	28.00
46 x 42	46.00	42.00	28.00
46 x 40	46.00	40.00	28.00
46 x 38	46.00	38.00	28.00
48 x 46	48.00	46.00	28.00
48 x 44	48.00	44.00	28.00
48 x 42	48.00	42.00	28.00
48 x 40	48.00	40.00	28.00







**Precision • Quality • Delivery**  
**Custom Solutions**



**PETROCHEMICAL**  
Flange Fittings Manufacturing Inc.

1744 Meyerside Drive, Suite # 103, Mississauga, ON L5T1A3 Canada  
Phone: 1-866-590-3835 | Fax: 1-866-315-8484  
[www.Petrocff.com](http://www.Petrocff.com) | [Sales@Petrocff.com](mailto:Sales@Petrocff.com)